

ULTRASONIC LEVEL METER
ULM-1000C

SONDAR



■ **Features**

- Easy Calibration
- Simple & convenient menu setting
- 5 key buttons
- Built-in temperature compensation sensor
- Echo processing using unique digital extraction technology

■ **Product Description**

The ULM-1000C Series is designated for measuring liquid level at various applications. ULM-1000C is a compact measuring instrument for continuous, non-contacting level measurement. There are two models for 6meter and 10meter. The design is modern, sophisticated and the menu interface is user friendly. 5 button for setting makes user easier, more convenience.

■ **Technical Specifications**

Dimension	Overall	117(D)×208.8(H) mm
	Sensor	56(D)×120(H) mm
Process Connection	2" NPT	
Weight	Nominal 1.5Kg	
Sensor Material	Polypropylene	
IR Rating	IP67	
Temperature	-20℃~85℃	
Pressure	Up to 2 Bar	
Measuring Range	0.3 ~ 6 m / 0.4~ 10 m	
Accuracy	0.2% of measured range	
Display Resolution	1mm	
Beam Angle	8° at -3dB	
Damping Rate	Adjustable 0.1m/min to 100m/min	
Temperature Compensation	Built-in temperature sensor	
Analog Output	4~20mA into max 750Ω	
Display	5 Digit Numeric LCD	
Power Supply	DC20~30V	
Supply Current	Less than 0.021A	
Certification	CE	

ULTRASONIC LEVEL METER
ULM-1000C

SONDAR

■ Dimension (unit: mm)

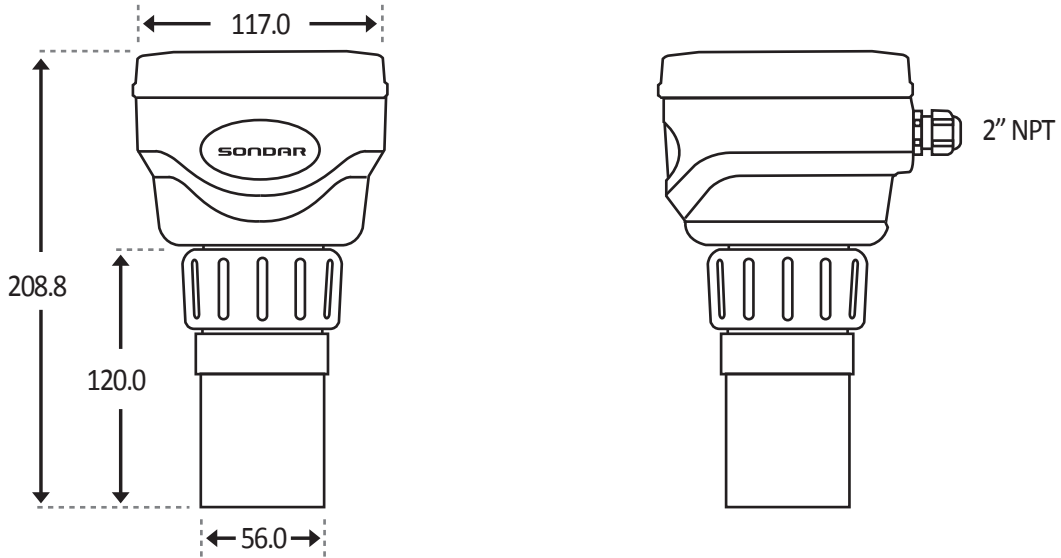

■ Terminal Connection

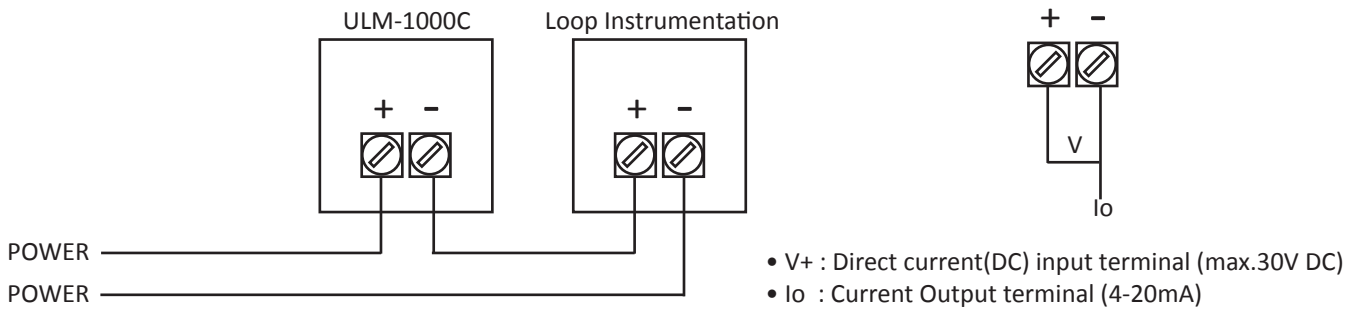

■ Ordering Code

ULM-10C-X **N-DC**

Range
- 06: 6meter
- 10: 10meter