

IP50DCD INTELLPAK DC Converter (Non-Isolator) User's Manual

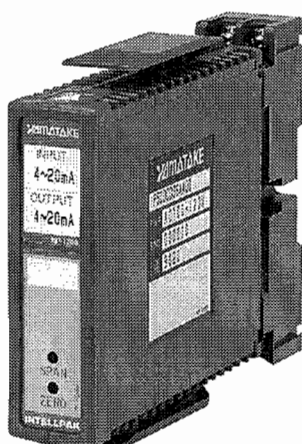

Yamatake Corporation

RESTRICTIONS ON USE

This product has been designed, developed and manufactured for general-purpose application in machinery and equipment.

Accordingly, when used in applications outlined below, special care should be taken to implement a fail-safe and/or redundant design concept as well as a periodic maintenance program.

- Safety devices for plant worker protection
- Start/stop control devices for transportation and material handling machines
- Aeronautical/aerospace machines
- Control devices for nuclear reactors

Never use this product in applications where human safety may be put at risk.

REQUEST

Ensure that this User's Manual is handed over to the user before the product is used.

Copying or duplicating this User's Manual in part or in whole is forbidden. The information and specifications in this User's Manual are subject to change without notice.

Considerable effort has been made to ensure that this User's Manual is free from inaccuracies and omissions.

If you should find any inaccuracies or omissions, please contact Yamatake Corporation.

In no event is Yamatake Corporation liable to anyone for any indirect, special or consequential damages as a result of using this product.

©1991 Yamatake Corporation ALL RIGHTS RESERVED

1. Introduction and Specifications

1. INTRODUCTION

The Intellpak IP50DCD is a thin plug-in system DC converter, which amplifies the converts each level of input signal into a unified signal output in the measurement control system.

2. SPECIFICATIONS

Input part	Input type	DC voltage, and DC current. Refer to Table 1.		
	Input impedance	Refer to Table 1.		
Output part	Output type	DC voltage, and DC current. Refer to Table 2.		
	Allowable load resistance	Refer to Table 2.		
General specifications	Accuracy	± 0.1% FS at the reference temperature of 23°C		
	Response time	25ms in 90% response		
	Power supply type	AC	DC	
	Rated power voltage	100/110/120V AC 50/60/Hz common 200/220/240V AC 50/60/Hz common	24V DC	
	Operating power voltage	80 to 132V AC 45 to 65Hz 170 to 264V AC 45 to 65Hz	24V DC ± 10%	
	Power consumption	Approx. 4.5VA		Approx. 2.2VA
	Starting current	—		0.11A or less
	Peak value and width of current with power ON	10A or less, 1ms		5A or less, 1ms
	Isolation between input and output	Non-isolation		
	Insulation resistance	100MΩ or more between I/O terminal and power terminal when measured by 500V DC megger.		
	Dielectric strength	2000V AC, 1 min between I/O terminal and power terminal		
	Power supply characteristic	±0.1% FS/90 to 132V AC or 170 to 264V AC	± 0.1% FS/24V DC ± 10%	
	Temperature characteristic	± 0.15% FS/10°C		
	Heat up time	Approx. 30 min after power ON		
	Operating ambient temperature	- 5 to +55°C, non-freezing		
	Storage ambient temperature	- 20 to +70°C, non-freezing		
	Operating ambient humidity	90% RH or less, non-dewing		
	Storage ambient humidity	90% RH or less, non-dewing		
	Vibration resistance	4.9m/s ² or less, 10 to 60Hz, 2 h in each direction of X, Y and Z (with vibration-absorbing bracket)	Not applicable when mounted on DIN rail	
	Shock resistance	490m/s ² or less, 3 times each vertically		
	Case material	Heat-resisting ABS resin		
	Case color	Gray, Munsell 2.5PB3.5/1		
	Wiring terminal screw	M3.5		
Installation	Installed on wall or DIN rail			
Mass	Approx. 200g (including the base socket)			

Standard accessories	Base socket, Part No. QN719A
Auxiliary parts (option)	Vibration-absorbing bracket, Part No. QN718A

2. Type Number

Configuration of Type Number

I II III IV V 0

Example: IP50DCD10AAT0

I	II	III	IV	V	Contents
Basic type No.	Input types	Output types	Power voltage	Additional processing	
IP50DCD					DC converter (non-isolated type)
Selected from Table 1. ▶					
	Selected from Table 2. ▶				
			A		100 to 240V AC 50/60Hz common
			B		200 to 240V AC 50/60Hz common
			D		24V DC
			0		None
			T		With tropical zone processing
			D		Inspection certificate provided
			B		With tropical zone processing and test data
			Y		Complying with the traceability certification

Table 1. Input Type

Additional type No.	Input type	Input impedance	Additional type No.	Input type	Input impedance
10	0 – 10mV	1 MΩ	23	± 1V	1 MΩ
11	0 – 100mV	1 MΩ	24	± 5V	1 MΩ
12	0 – 1V	1 MΩ	25	± 10V	1 MΩ
13	0 – 5V	1 MΩ	30	0 – 10μA	1 kΩ
14	1 – 5V	1 MΩ	31	0 – 100μA	100 Ω
15	0 – 10V	1 MΩ	32	0 – 1mA	100 Ω
16	0 – 50mV	1 MΩ	33	0 – 10mA	50 Ω
17	0 – 60mV	1 MΩ	34	0 – 16mA	50 Ω
18	0 – 30V	1 MΩ	35	0 – 20mA	50 Ω
19	0 – 50V	1 MΩ	36	4 – 20mA	50 Ω
20	± 10mV	1 MΩ	40	± 1mA	100 Ω
21	± 50mV	1 MΩ	41	± 20mA	50 Ω
22	± 100mV	1 MΩ	—	—	—

Table 2. Output Type

Additional type No.	Output type	Allowable load resistance	Additional type No.	Output type	Allowable load resistance
A	4 – 20mA	750 Ω max.	R	± 10V	5kΩ min.
B	1 – 5mA	3 kΩ max.	—	—	—
C	2 – 10mA	1.5 kΩ max.	—	—	—
D	0 – 1mA	15 kΩ max.	—	—	—
E	0 – 10mA	1.5 kΩ max.	—	—	—
F	0 – 16mA	937 Ω max.	—	—	—
G	0 – 20mA	750 Ω max.	—	—	—
H	1 – 5V	2.5 kΩ min.	—	—	—
J	0 – 10mV	10 kΩ min.	—	—	—
K	0 – 100mV	100 kΩ min.	—	—	—
L	0 – 1V	500 Ω min.	—	—	—
N	0 – 5V	2.5 kΩ min.	—	—	—
P	0 – 10V	5 kΩ min.	—	—	—

3. Circuit Block Diagram

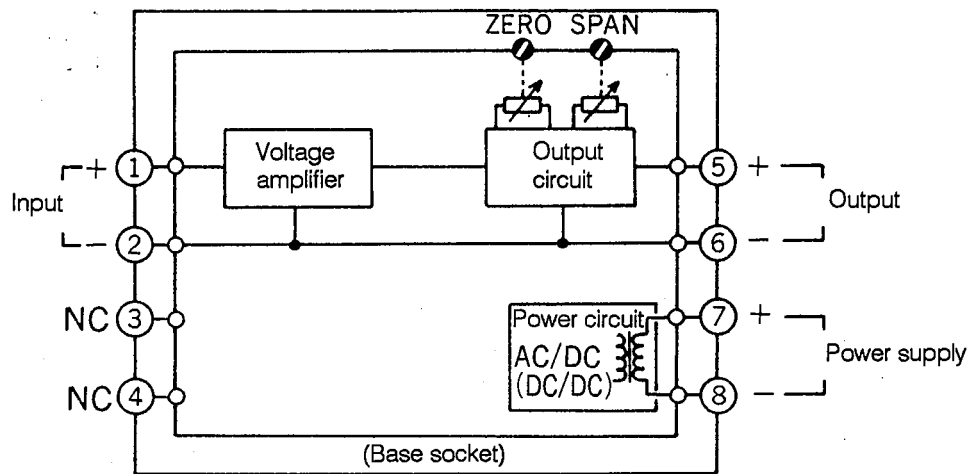

4. External Dimension Drawing

External Dimension Drawing

Unit: mm

Base socket Part No. QN719A

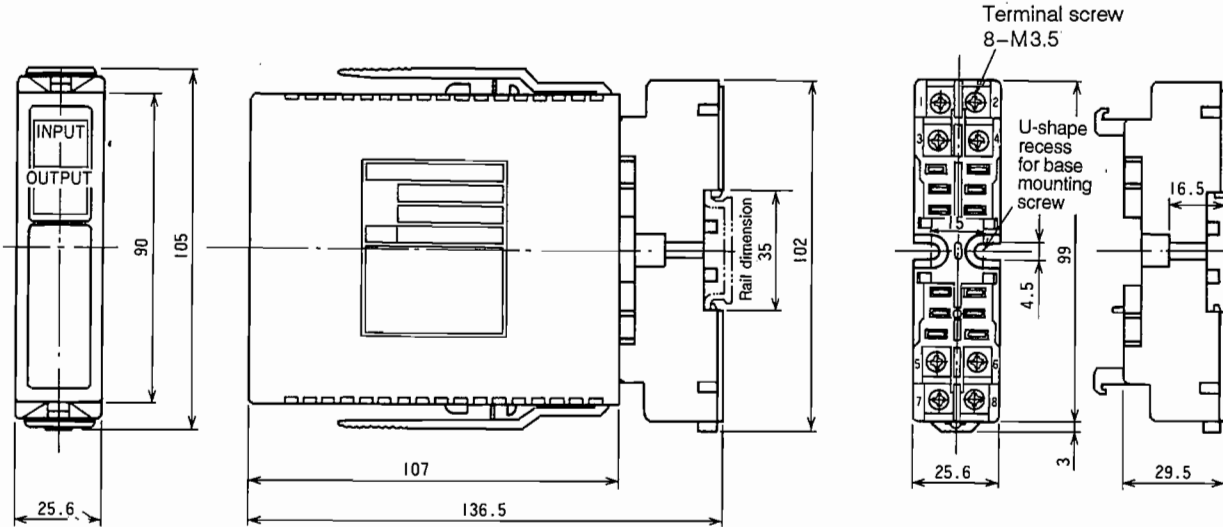

With the Vibration-absorbing Bracket Mounted

Vibration-absorbing bracket Part No. QN718A

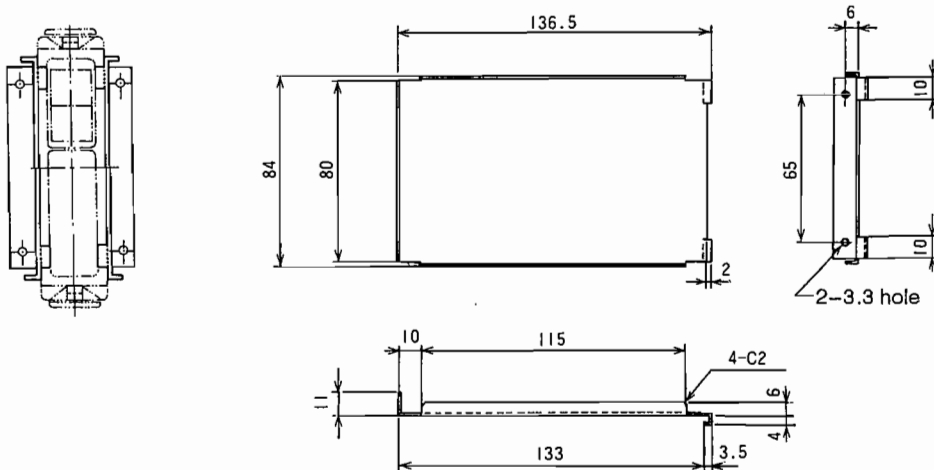

Material: Cold-rolled steel plate SPCC t1
Galvanized, and chromatically processed

5. Installation

1. CAUTIONS IN INSTALLATION

(1) Handling

When removing or mounting the main unit from/to the socket, be sure to turn OFF the power supply and the input signal in advance to prevent trouble from occurring.

(2) Installation

(a) When the equipment is to be installed in a location subject to dust or chips, house it in a dust-proof cabinet with a heat radiation function.

(b) Avoid exposing the equipment to vibration and shocks as much as possible, since they may cause malfunctions.

(3) Wiring

(a) Don't lay the power line, input signal line, and output signal line near a noise generator, or relay drive line.

(b) Avoid clamping these lines together with a noise superimposed line or putting them together in the same duct.

(c) This equipment can be operated as soon as the power supply is turned ON. However, for optimum performance, allow 30 minutes of energizing time before operating.

(4) Short circuit of output terminals

In the case of the voltage output, avoid shorting the output terminals for a long time.

2. INSTALLATION METHOD

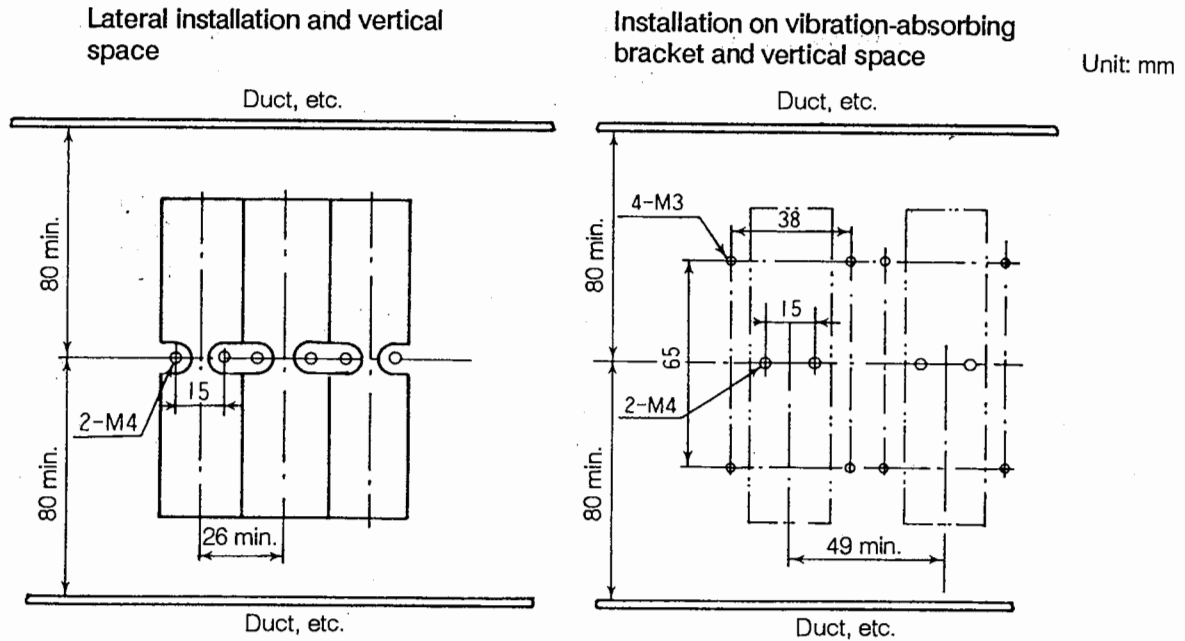

Cautions:

- ① When installing the equipment on a wall where there is vibration, use the vibration-absorbing bracket (option, QN718A). Where there is vibration, the equipment cannot be installed on the DIN rail.
- ② When the output of the main unit is to be A/D converted, use the integral type A/D converter. When the high speed A/D converter for sequential comparison, etc. is to be used, check the operation by the combination test in advance.

3. MOUNTING AND REMOVING TO/FROM THE DIN RAIL

(1) How to fix the socket

Hook the click to the rail with the slider on the socket bottom-down, and push in the lower part of the socket in the direction of the arrow, as shown in the figure, until it is fixed.

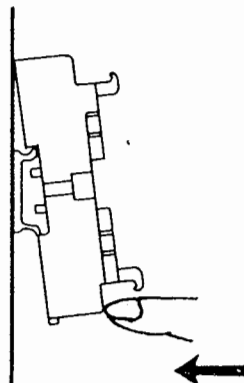

(2) How to fix the main unit to the socket

Set the main unit so that the label can be properly read, and insert it straight and even. At this time, insert it until the hooks are restored parallel with the main unit case, and they are completely engaged with the projection of the socket.

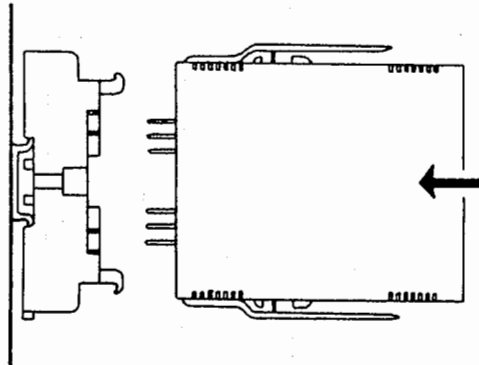

(3) How to remove the main unit from the socket

Push in the main unit sufficiently, and spread the upper and lower hooks simultaneously, and then extract the main unit forward straight and even. Note that the socket may be damaged if it is extracted without spreading both hooks sufficiently.

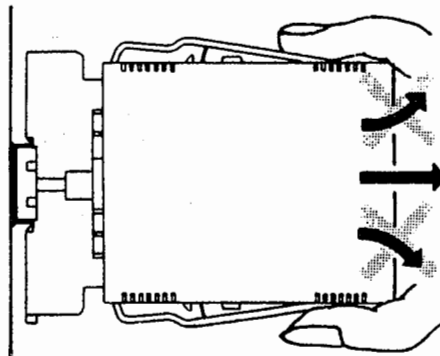

(4) How to remove the socket

Insert a screwdriver in the slider groove of the socket. While pulling the screwdriver in the direction of the arrow as shown in the diagram, draw the lower part of the socket forward until it is removed.

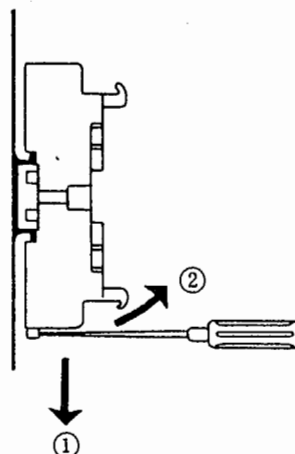

6. Wiring

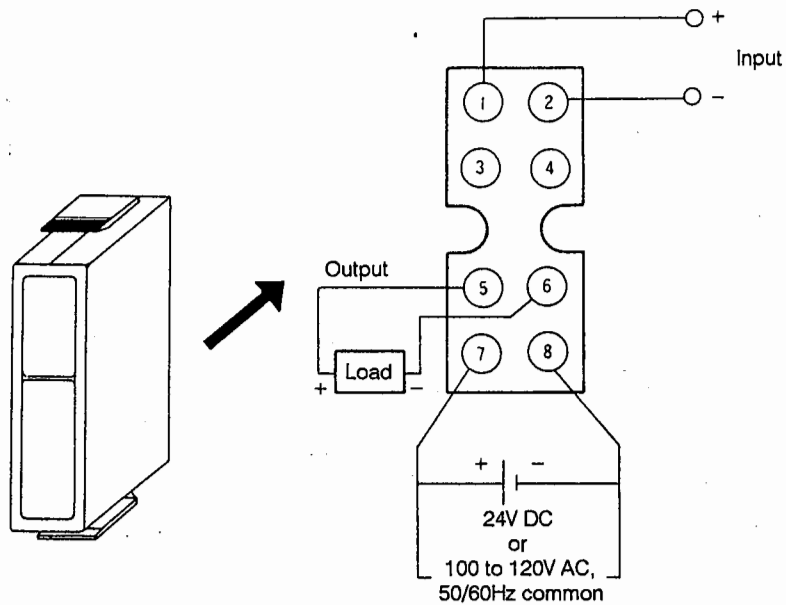

Terminal No.	Symbol	Contents
1	Input	Connect the specified input signal.
2		
3		Blank terminal
4		
5	Output	The signal based on the input/output specification is output.
6		
7	Power supply	Connect the power supply of the rated voltage.
8		

- When the DC current exceeding 50mA DC is to be input, apply the input signal of 60mV DC FS to this equipment in combination with a shunt.
- When the DC voltage exceeding 300V DC is to be input, apply the input signal of 1mA DC FS to this equipment in combination with a multiplier.

7. Adjustment

1. ZERO AND SPAN ADJUSTING METHOD

Since this equipment has been properly calibrated at the time of shipping, each ZERO and SPAN trimmer need not be adjusted so far as the equipment is operated according to the manufacturing specifications.

If matching with the connected equipment or the routine calibration is required, observe the following procedures. This calibration shall be made 30 min after the power supply is turned ON, using a signal source (such as standard voltage, current generator), and measuring instruments (voltmeter, ammeter), whose accuracies are 10 times or more each as high as the tolerance of this equipment.

The adjustable range of zero and span are approx. + 10% FS each. Multi-revolution trimmers are used for these adjustments. Note that these multi-revolution trimmers are not provided with stoppers.

1) Zero adjustment

Apply a minimum value within the input range to the input terminals, and turn the zero trimmer until the output signal reaches the minimum value within the output range.

2) Span adjustment

Apply the maximum value within the input range to the input terminals, and turn the span trimmer until the output signal reaches the maximum value within the output range.

		With the output of 4 to 20mA	With the output of 0 to 20mA
Zero adjustment	<p>The zero point is shifted upward.</p> <p>(↑) ZERO</p> <p>The zero point is shifted downward.</p>		
Span adjustment	<p>The span is widened.</p> <p>(↑) SPAN</p> <p>The span is narrowed.</p>		

2. OPERATION AGAINST EXCESSIVE INPUT

1) Excessively large input

When a signal exceeding the upper limit of the input range is input, the output signal is increased in proportion to the input up to approx. 120% FS. Even when a greater input signal is input, the output signal won't be increased beyond approx. 120% FS due to the operation of the built-in limiter circuit.

2) Excessively small input

If a signal lower than the lower limit of the input range is input, the output operation is as follows;

(a) With the current output, the output signal is reduced nearly proportional to the input down to approx. -20% FS, but no negative current is output.

(b) With the voltage output, the output signal is reduced nearly proportional to the input down to -120% FS. Even when a smaller signal is input, the output signal won't be reduced below approx. -120% FS due to the operation of the built-in limiter circuit.

3) Excessive load

(a) Current output

When the output exceeds the "allowable load resistance range", the output is nearly proportional to the input until the voltage between the output terminals becomes approx. 16V. If this range is exceeded, the output is saturated, causing a larger error.

(b) Voltage output

When the output is reduced below the "allowable load resistance range", the output is saturated, causing a larger error.

azbil

Yamatake Corporation
Advanced Automation Company

1-12-2 Kawana Fujisawa
Kanagawa 251-8522 Japan

URL: <http://www.azbil.com>

Printed on recycled paper. (06)

Specifications are subject to change without notice.

Printed in Japan.
1st Edition: Issued in Feb. 1991
4th Edition: Issued in Oct. 2006(B)