

# SDC35/36 Quick Reference Guide

This guide offers a summary of key operations, parameter flowcharts, and settings, for convenient reference at the operation site. This guide is made for repeated use. Dirt wipes off easily and even notes written with an oil-based felt-tip pen can be removed with an eraser. If more detailed information on the SDC35/36 is needed, refer to the user's manual: CP-SP-1150E for installation and configuration.

The most convenient way to configure the SDC35/36 is with the Smart Loader Package (model No. SLP-C35J50). Please contact Yamatake Corporation or a distributor for more information.

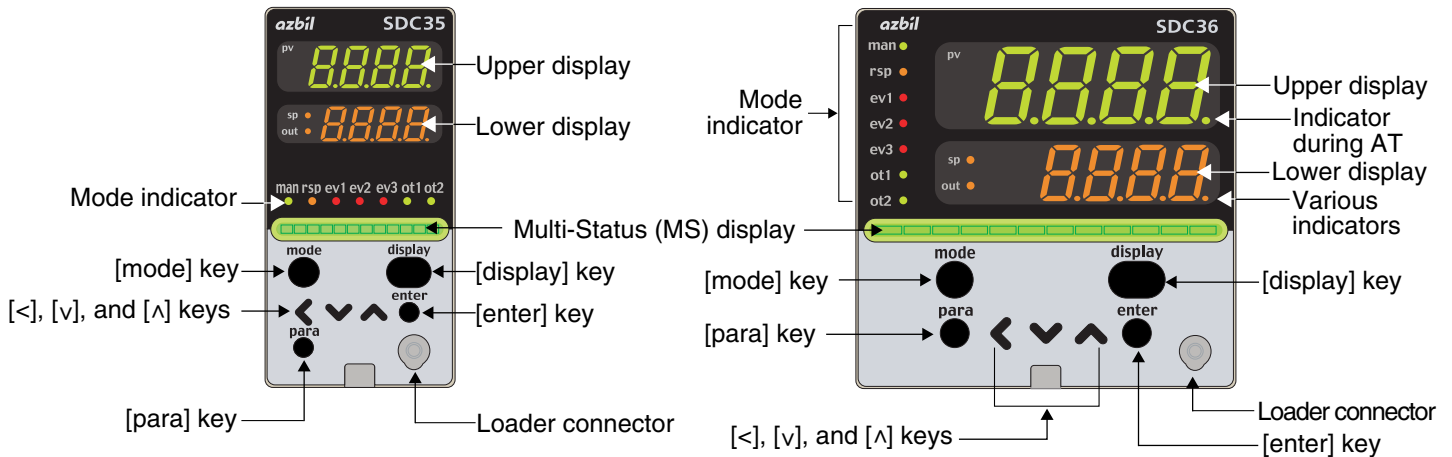

Upper display	This display shows either the PV value or the display value and set value for each displayed item. If an alarm is triggered, the normal display and alarm code are displayed alternately. During auto tuning (AT), the rightmost decimal point flashes twice repeatedly.
Lower display	This display shows either the SP/MV/CT or the display value and set value for each displayed item. The decimal point at the right end digit shows the RUN/READY mode or communication status.
Multi-Status (MS) display	Turns ON in READY mode or when an alarm occurs, depending on the ON conditions and the current status. When lit, in addition to flashing and reciprocating between left and right, it performs MV graph, DI monitor, internal event monitor, and other display functions.
Mode indicators	<p>man: Lights when MANUAL (AUTO mode if not lit)</p> <p>rsp: Lights when RSP</p> <p>ev1, ev2, ev3: Lights when event relays are ON</p> <p>ot1, ot2: Lights when the control output is ON (always lit when the current output is used)</p>
[mode] key	<ul style="list-style-type: none"> <li>When this key is pressed and held for more than 1 second in the operation display mode, any of the following operations from 0 to 7 which have been set previously can be executed</li> <li>0 : Mode key does not operate (Initial value)</li> <li>1 : AUTO/MANUAL mode selection</li> <li>2 : RUN/READY mode selection</li> <li>3 : AT (Auto Tuning) start/stop selection</li> <li>4 : LSP (Local SP) group selection</li> <li>5 : Release all DO (Digital Output) latches</li> <li>6 : LSP/RSP mode selection</li> <li>7 : ON/OFF selection of communication DI</li> <li>When pressing the [mode] key in the setup display mode, the display is changed to the operation display</li> </ul>
[display] key	This key is used to change the display item in the operation display mode. When pressing this key in the bank selection, bank setup, or user function setup display mode, the display is changed to the operation display.
[para] key	When this key is kept pressed for 2 sec. or longer in the operation display mode, the display is then changed to the setup display.
[<], [v], [^] keys	These keys are used to increase or decrease the numeric value, or to shift the digit. The [v] and [^] keys are used to change the bank or display item.
[enter] key	This key is used to begin changing settings (display goes from lit to flashing) and to finalize new settings (display goes from flashing to steadily lit).
Loader connector	This connector is used for connecting to a personal computer using the dedicated cable supplied with the Smart Loader Package.

# Flowchart of key operations and displays

When the power is turned ON

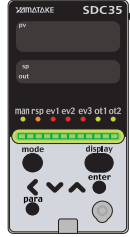

Upper and lower displays remain off for 5s after power ON. Each mode indicator lights sequentially, and then the operation display appears.

User function

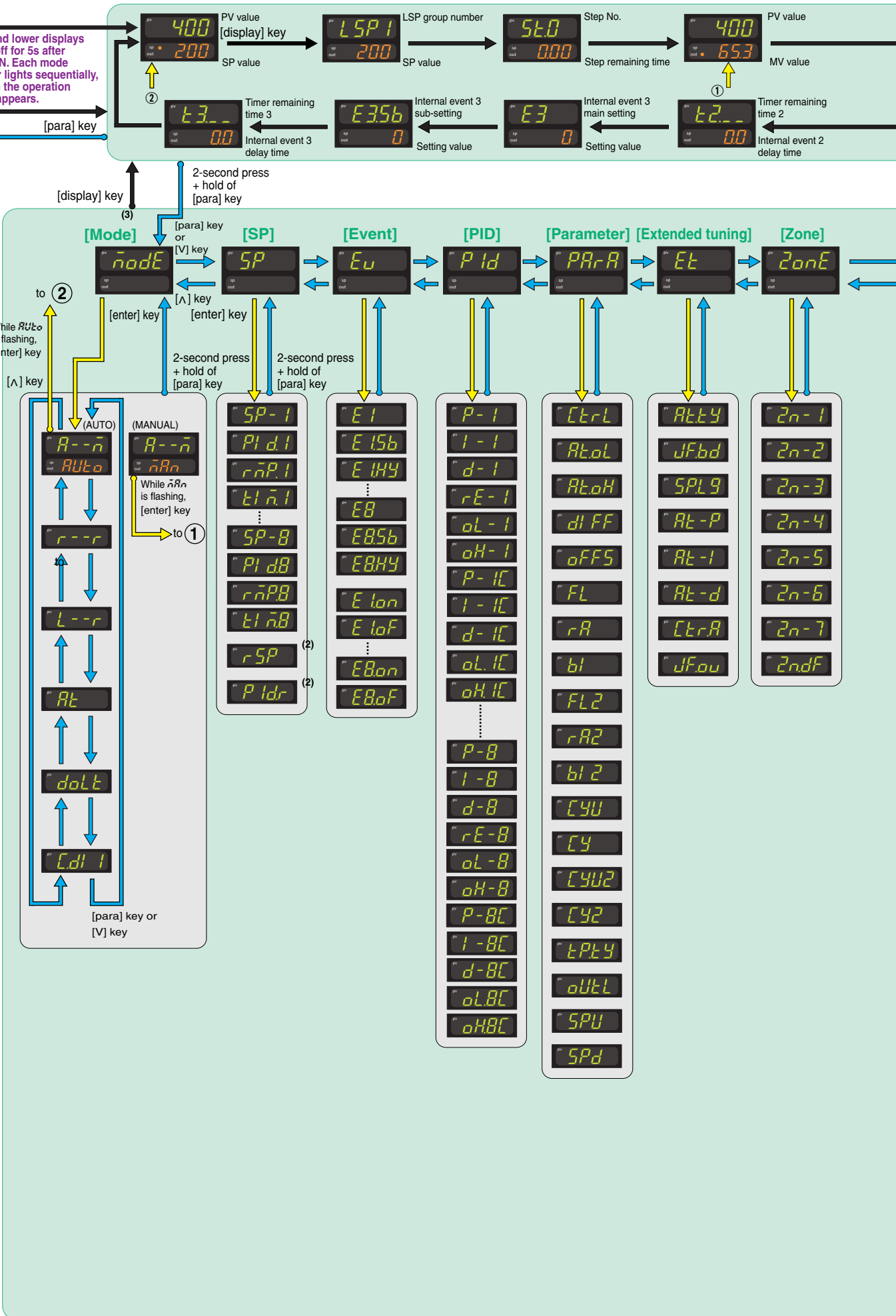
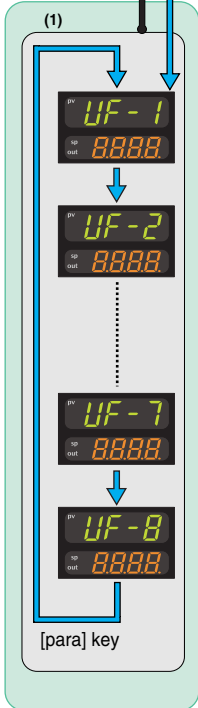

- Some items are not displayed depending on the availability of optional functions, model number, display setup (C73 to C78) and display level (C79).
- Pressing [display] while bank item or user function item is displayed has the effect of canceling and returning to the operation display item.

### Operation displays

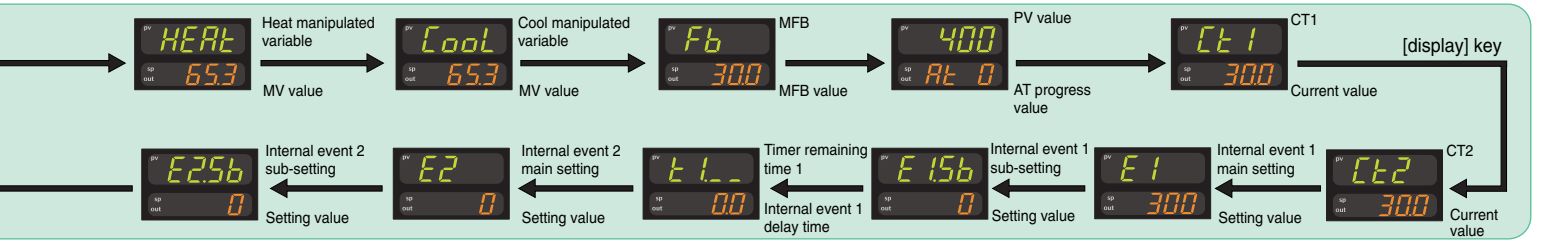

### Bank selection

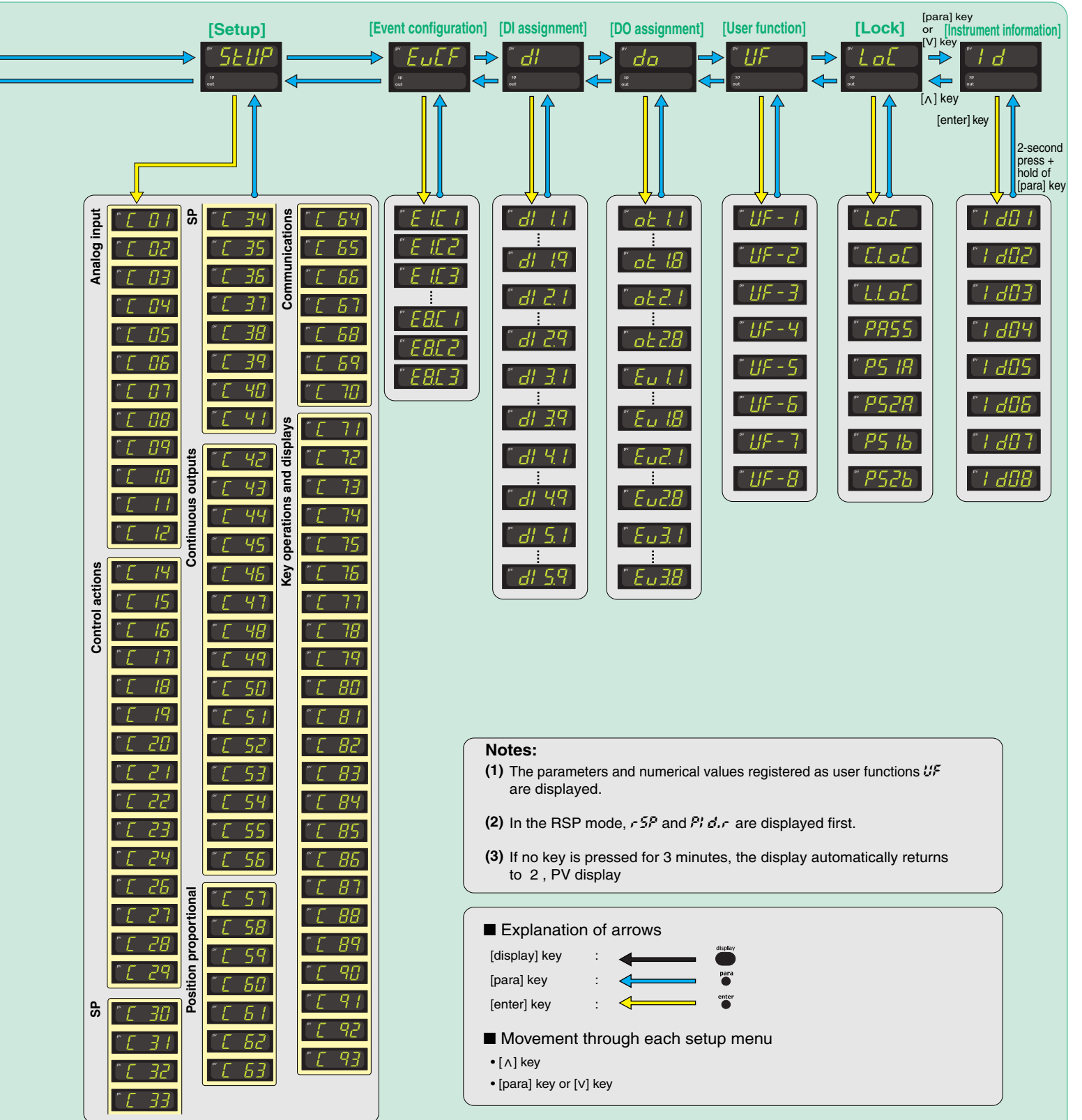

# Operation examples

**Red letters** : Items before operation

**Blue letters** : Items during operation

## Setup of PV input range type

- Press [display] once to get the operation display.

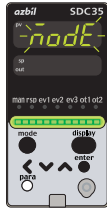

If no sensor is connected, an alarm for abnormal PV input (any one from  $R_{L0}$  to  $R_{L1}$ ) may appear on the upper display.
- Press and hold [para] for more than 2s to get the parameter setup display.  $n\alpha d E$  flashes on the upper display.

- Press [v] or [^] repeatedly, and  $S E U P$  flashes on the upper display.

- Press [enter]. The current set value for  $E 0$  (PV input range type) is displayed.



- Press [enter]. The rightmost digit on the lower display flashes and its value can be changed. Press [<], [v] or [^] to change to the desired sensor type in the PV input range list. Then press [enter] to finalize your selection. (If the number is flashing, the [enter] key has not yet been pressed, and the setting has not yet been saved.)





## Execution of auto tuning (AT)

AT forces ON/OFF of the MV a number of times (a limit cycle) to calculate PID values. Check that this operation does not create any problems for the associated equipment before executing AT.

- Press [display] once to get the operation display.



- Press and hold [para] for more than 2s to get the parameter setup display.  $n\alpha d E$  flashes on the upper display.

- Press [enter] or [<] to get  $R - n$  on the upper display and  $R L o F$  on the lower display.





If the control method is ON/OFF control and if Bit 3 (AT stop/start display) of the mode display setting ( $E 73$ ) is set to "disabled: 0," nothing is displayed.
- Press [v] as needed until  $R L$  and  $R L o F$  appear on the upper and lower displays respectively.

- When [enter] is pressed,  $R L o F$  flashes on the lower display.



The display flashes only in RUN and AUTO modes, and only if there is no PV problem. Also, if DI is set to "AT stop/start", the display does not flash and the setting cannot be changed.
- Press [v] or [^] once, and  $R L o F$  flashes on the lower display.

- If [enter] is pressed,  $R L o n$  remains steadily lit and AT begins. During AT, the rightmost decimal point flashes twice repeatedly. (When AT is done, the light goes off and the new PID values go into effect.)





During the AT process, if the mode is changed to READY or MANUAL, if PV input is faulty, or if a power failure occurs, AT stops automatically without changing the PID values. AT can also be stopped by changing the setting from  $R L o n$  to  $R L o F$  (return to step 4 above).

## Setup of event operation type

In this example, the event 1 operation type is set to deviation high limit.

- Press [display] once to get the operation display.



- Press and hold [para] for more than 2s to get the parameter setup display.  $n\alpha d E$  flashes on the upper display.

- Press [v] or [^] repeatedly to get  $E U C F$  flashing on the upper display.



- Press [enter] to get  $E 1 C 1$  on the upper display and 0 is displayed on the lower display.



0 on the lower display indicates that the event operation type is set to "none."
- When [enter] is pressed, the rightmost digit on the lower display flashes. Press [v] or [^] to get 4 flashing on the display.



4 on the lower display indicates that the event operation type is set for deviation high limit.
- Press [enter], and the displayed value changes from flashing to continuously lit and the displayed value is set.





Similarly, use  $E 2 C 1$  to set the event 2 operation type, and use  $E 3 C 1$  for event 3.

## Setup of SP value

- Press [display] repeatedly so that the orange SP indicator lights up on the lower display. The operation display now shows the SP.

- If [enter] is pressed, the rightmost digit on the lower display flashes and numerical value can be changed.

- Press [<], [v] or [^] to change to the desired SP value. The flashing of the number indicates that the setting has not yet been finalized.



If an SP limit is in effect, the numerical value cannot be changed to a value above the limit. The SP limit must be changed first.
- If [enter] is pressed, the displayed value is set and the display changes from flashing to continuously lit.







If the [display] key is pressed without pressing [enter] key, the status returns to that of step 1.

- For step numbers indicated in red like **2**, the following precaution applies:

If the key lock is set, the numerical value does not flash, and the value cannot be changed. To change a numerical value, cancel the key lock first.





## AUTO/MANUAL mode selection

<p><b>1</b> Press [display] once to get the operation display.</p>  <p>The [mode] key can be used for 1 of 7 different operations. The initial (factory) setting is "AUTO/MANUAL selection".</p>	<p><b>2</b> Press and hold [mode] for more than 2s, <math>\bar{n}oDE</math> flashes on the lower display.</p>  <p>If the control method is set to "ON/OFF control" and if the DI assignment is "AUTO/MANUAL," the display does not blink and the setting cannot be changed.</p>
<p><b>3</b> When <math>\bar{n}oDE</math> appears, stop pressing [mode]. The MV is shown on the lower display. The rightmost digit of the MV on the lower display flashes and its value can be changed.</p> 	<p><b>4</b> Press [<math>\leftarrow</math>], [<math>\vee</math>] or [<math>\rightarrow</math>] to change to the desired MV value. Even while the number is flashing, the MV is changed at the same time that the number is changed.</p> 

For the flashing MV in step 3, either bumpless transition (the same value as before the change) or preset MANUAL value (the value set in setup  $\bar{C}20$ ) can be selected (in setup  $\bar{C}19$ , Output operation after AUTO-MANUAL change).

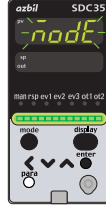
## Execution of position proportional control auto adjust







When control output is R1 (motor relay output) and setup  $\bar{C}57$  is "0" (initial value) or "1", the following position proportional control auto adjust is necessary.

<p><b>1</b> Press [display] once to get the operation display.</p> 	<p><b>2</b> Press and hold [para] for more than 2s to get the parameter setup display. <math>\bar{n}oDE</math> flashes on the upper display.</p> 
<p><b>3</b> Press [<math>\vee</math>] or [<math>\leftarrow</math>] repeatedly until <math>\bar{S}tUP</math> is flashing on the upper display.</p> 	<p><b>4</b> Press [enter] to get <math>\bar{C}60</math> on the upper display. Press [<math>\leftarrow</math>], [<math>\vee</math>] or [<math>\rightarrow</math>] to change to <math>\bar{C}60</math>. (<math>\bar{C}60</math>: position proportional control auto adjust)</p> 
<p><b>5</b> If [enter] is pressed, the lower display flashes. Press [<math>\vee</math>] or [<math>\leftarrow</math>] to get <math>\bar{t}</math>. Press [enter] and auto adjustment starts.</p> 	<p><b>6</b> <math>\bar{C}A.CL</math> is displayed on the upper display and open contact is ON. The lower display shows the MFB count value and when count is stable, <math>\bar{C}A.OP</math> is displayed on the upper display and closed contact is ON. When the count value is stable, auto adjust completes to get operation display.</p> 

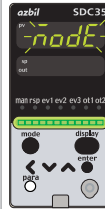
After starting auto adjust, press [display] key to stop auto adjust. During auto adjust the key operation except [display] key of stopping auto adjust is impossible.

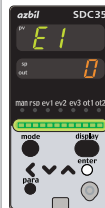
## Setup of event value

In this example, the event set value and hysteresis for the event 1 operation type is set to deviation high limit.

<p><b>1</b> Press [display] once to get the operation display.</p> 	<p><b>2</b> Press and hold [para] for more than 2s to get the parameter setup display. <math>\bar{n}oDE</math> flashes on the upper display.</p> 
<p><b>3</b> Press [<math>\vee</math>] twice or [<math>\leftarrow</math>] repeatedly, and <math>\bar{E}u</math> flashes on the upper display.</p> 	<p><b>4</b> Press [enter] to get <math>\bar{E}1</math> on the upper display and <math>\bar{0}</math> is displayed on the lower display.</p>  <p><math>\bar{0}</math> on the lower display indicates that the event main setting is "0".</p>
<p><b>5</b> If [enter] is pressed, the rightmost digit on the lower display flashes, and can be changed. Press [<math>\leftarrow</math>], [<math>\vee</math>], or [<math>\rightarrow</math>], and change to the desired value for event set value. In this case, the flashing of the numerical value implies that it is not yet set.</p> 	<p><b>6</b> If [enter] is pressed, the changed numerical value is set and changes from flashing to continuously lit.</p> 
<p>Similarly, use <math>\bar{E}2</math> to set a value for event 2, and <math>\bar{E}3</math> to set a value for event 3.</p>	
<p><b>7</b> To continue from this point and set hysteresis as well, press [<math>\vee</math>] twice or [<math>\leftarrow</math>] repeatedly to get <math>\bar{E}1.HY</math> on the upper display. The lower display says 5.</p>  <p>5 on the lower display indicates that the event hysteresis is "5".</p>	<p><b>8</b> In the same way that event settings were changed, press [enter] to make the number flash, and then press [<math>\leftarrow</math>], [<math>\vee</math>] or [<math>\rightarrow</math>] to change to the desired setting for hysteresis. After that, press [enter] to finalize the setting.</p> 

Similarly, use  $\bar{E}2.HY$  to set a value for event 2, and  $\bar{E}3.HY$  to set a value for event 3.

# List of parameter

- Essential parameters for PV measurement and control
- Basic parameters
- Required parameters when using optional functions

## List of operation displays

Display	Item	Contents	Initial value	Setting value
Upper display: PV Lower display: SP				
PV SP	SP(Target value)	SP low limit to SP high limit	0	
LSP (Display example) LSP	LSP group number (1st digit-the right end digit)	1 to LSP system group (Max. 4)	1	
St (Display example) Step No. Step remaining time	Step operation remaining time	Setting is disabled. The step No. distinguishes up ramp, down ramp, and soak.	-	
PV MV	MV (Manipulated Variable)	-10.0 to +110.0% Setting is enabled in MANUAL mode (Numeric value flashed)	-	
HEMV Numeric value	Heat MV (Manipulated Variable)	Setting is disabled.	-	
Cool Numeric value	Cool MV (Manipulated Variable)	-10.0 to +110.0%	-	
Fb Numeric value	MFB (Motor opening feedback value)	Setting is disabled. +10.0 to +110.0% Flashing when the value is 0.0 to 100.0% during estimate.	-	
PV Rt (Display example)	AT progress display (1st digit-the right end digit)	Setting is disabled.	-	
ct1 Numeric value	CT current value 1	Setting is disabled.	-	
ct2 Numeric value	CT current value 2	Setting is disabled.	-	
E1 Numeric value	Internal Event 1 main setting	-1999 to +9999U or 0 to 9999U	0	
E1.5b Numeric value	Internal Event 1 sub setting			
E1. (Display example) Numeric value	Internal Event 1 remaining time	Setting is disabled. "r", is displayed at the right end digit when using the ON delay time, and "L", the OFF delay time.	-	
E2 Numeric value	Internal Event 2 main setting	Same as Internal Event 1 main setting	0	
E2.5b Numeric value	Internal Event 2 sub setting	Same as Internal Event 1 sub setting	0	
E2. (Display example) Numeric value	Internal Event 2 remaining time	Same as Internal Event 1 remaining time	-	
E3 Numeric value	Internal Event 3 main setting	Same as Internal Event 1 main setting	0	
E3.5b Numeric value	Internal Event 3 sub setting	Same as Internal Event 1 sub setting	0	
E3. (Display example) Numeric value	Internal Event 3 remaining time	Same as Internal Event 1 remaining time	-	

## List of parameter setting displays

### Mode bank

Display	Item	Contents	Initial value	Setting value
R--n	AUTO/MANUAL	R: AUTO mode n: MANUAL mode	AUTO	
---r	RUN/READY	r: RUN mode r: READY mode	RUN	
L---r	LSP/RSP	LSP: LSP rSP: RSP	LSP	
St	AT stop/start	St: AT stop St: AT start	AT stop	
oL, oH	Release all DO latches	oL: Latch continue oH: Latch release	Latch continue	
ct, dt 1	Communication D11	dt, oF: OFF dt, on: ON	OFF	

### SP bank

Display	Item	Contents	Initial value	Setting value
rSP	RSP	Setting is disabled.	-	
Pid	PID group number (RSP)	1 to 8	1	
SP 1 to SP 8	SP of LSP 1 group to 8 group	SP low limit to SP high limit	0	
Pid 1 to Pid 8	PID group number (LSP 1 to 8)	1 to 8	1	
rSP 1 to rSP 8	Ramp (LSP 1 to 8)	0 to 9999	0	
E1.1 to E1.8	Time (LSP 1 to 8)	0.0 to 999.9 or 0 to 9999	0	

### Event bank

Display	Item	Contents	Initial value	Setting value
E1 to E8	Internal Event 1 to 8 main setting	-1999 to +9999 or 0 to 9999	0	
E1.5b to E8.5b	Internal Event 1 to 8 sub setting	(The decimal point position may vary so that it meets the operation type of the internal event)	0	
E1.MY to E8.MY	Internal Event 1 to 8 hysteresis	0 to 9999 (The decimal point position may vary so that it meets the operation type of the internal event)	5	
E1.on to E8.on	Internal Event 1 to 8 ON delay time	0.0 to 999.9 or 0 to 9999	0	
E1.oF to E8.oF	Internal Event 1 to 8 OFF delay time			

### PID bank

Display	Item	Contents	Initial value	Setting value
P-1 to P-8	Proportional band (PID1 to 8)	0.1 to 999.9%	5.0	
I-1 to I-8	Integral time (PID1 to 8)	0 to 9999s or 0.0 to 999.9s (No integration control action when set at "0")	120	
D-1 to D-8	Derivative time (PID1 to 8)	0 to 9999s or 0.0 to 999.9s (No derivative control action when set at "0")	30	
rE-1 to rE-8	Manual reset (PID1 to 8)	-10.0 to +110.0%	50.0	
oL-1 to oL-8	MV low limit (PID1 to 8)	-10.0 to +110.0%	0.0	
oH-1 to oH-8	MV high limit (PID1 to 8)	-10.0 to +110.0%	100.0	
P-1c to P-8c	Proportional band (cool) (PID1 to 8)	0.1 to 999.9%	5.0	
I-1c to I-8c	Integral time (cool) (PID1 to 8)	0 to 9999s or 0.0 to 999.9s (No integration control action when set at "0")	120	
D-1c to D-8c	Derivative time (cool) (PID1 to 8)	0 to 9999s or 0.0 to 999.9s (No derivative control action when set at "0")	30	
oL-1c to oL-8c	Output low limit (cool) (PID1 to 8)	-10.0 to +110.0%	0.0	
oH-1c to oH-8c	Output high limit (cool) (PID1 to 8)	-10.0 to +110.0%	100.0	

### Parameter bank

Display	Item	Contents	Initial value	Setting value
ct, dt	Control method	0: ON/OFF control 1: Fixed PID	0 or 1	
Rt, oL	MV low limit at AT	-10.0 to +110.0%	0.0	
Rt, oH	MV high limit at AT	-10.0 to +110.0%	100.0	
dt, FF	Differential (for ON/OFF control)	0 to 9999U	5	
oFFFS	ON/OFF control action point offset	-1999 to +9999U	0	
FL	PV filter	0.0 to 120.0s	0.0	
rR	PV ratio	0.001 to 9.999	1.000	
b1	PV bias	-1999 to +9999U	0	
FL2	RSP filter	0.0 to 120.0s	0.0	
rR2	RSP ratio	0.001 to 9.999	1.000	
b2	RSP bias	-1999 to +9999U	0	
ct1	Time proportional cycle unit 1	0 to 3 *1	0	
ct2	Time proportional cycle 1	5 to 120s or 1 to 120s *2	10 or 2	
ct3	Time proportional cycle unit 2	0 to 3 *1	0	
ct4	Time proportional cycle 2	5 to 120s or 1 to 120s *2	10 or 2	
ct5	Time proportional cycle mode	0: Controllability aiming type 1: Operation end service life aiming type (Only ON/OFF operation within Time proportional cycle)	0 or 1	
oVL	Output variation limit	0.0 to 999.9% (No limit when set at "0.0U")	0.0	
SPu	SP up ramp	0.0 to 999.9U (No ramp when set at "0.0U")	0.0	
SPd	SP down ramp		0.0	

\*1 0: Unit of "1s" 1: Fixed at 0.5s 2: Fixed at 0.2s 3: Fixed at 0.1s  
\*2 5 to 120s when output includes the relay output  
U: Unit Maximum unit of Industrial volume in PV range (°C, Pa/L/min, etc.)

### Extended tuning bank

Display	Item	Contents	Initial value	Setting value
Rt, EY	AT type	0: Normal 1: Immediate response 2: Stable *1	1	
uF, bsd	Just-FITTER setting band	0.00 to 10.00	0.30	
SP, I3	SP lag constant	0.0 to 999.9	0.0	
Rt-P	Proportional band tuning factor at AT	0.00 to 99.99	1.00	
Rt-I	Integral time adjust at AT	0.00 to 99.99	1.00	
Rt-D	AT Derivative time adjust	0.00 to 99.99	1.00	
ct, R	Control algorithm	0: PID (Conventional PID) 1: Ra-PID (high-performance PID)	0	
uF, ov	Just-FITTER overshoot suppression factor	0 to 100	0	

\*1 Normal = Standard control characteristics, Immediate response = Control characteristics that respond immediately to external disturbance, Stable = Control characteristics having less up/down fluctuation of PV

### Zone bank

Display	Item	Contents	Initial value	Setting value
zo-1 to zo-7	Zone 1 to 7	-1999 to +9999U	9999U	
zodF	Zone hysteresis	0 to 9999	5U	

## List of setup setting displays

### Setup bank

Display	Item	Contents	Initial value	Setting value
ct1	PV input range type	For details, refer to the PV Input Range Table	88	
ct2	Temperature unit	0: Celsius (°C) 1: Fahrenheit (°F)	0	
ct3	Cold junction compensation	0: Performed (internal) 1: Not performed (external)	0	
ct4	Decimal point position	0: No decimal point 1 to 3: 1 to 3 digits below decimal point	0	
ct5	PV input range low limit	When the PV input type is DC voltage/DC current,	0	
ct6	PV input range high limit	-1999 to +9999U	1000	
ct7	SP low limit	PV input range low limit to PV input range high limit	0	
ct8	SP high limit	PV input range low limit to PV input range high limit	1000	
ct9	PV square root extraction dropout	0.0 to 100.0% (PV square root extraction is not performed when set at "0.0")	0.0	
ct10	RSP input type	0: 4 to 20mA 1: 0 to 20mA 2: 0 to 5V 3: 1 to 5V 4: 0 to 10V	0	
ct11	RSP input range low limit	-1999 to +9999U	0	
ct12	RSP input range high limit		1000	
ct13	Control action (Direct/Reverse)	0: Heat control (Reverse action) 1: Cool control (Direct action)	0	
ct15	Output operation at PV alarm	0: Control calculation is continued. 1: Output at PV alarm is output.	0	
ct16	Output at PV alarm	-10.0 to +110.0%	0.0	
ct17	Output at READY (Heat)	-10.0 to +110.0%	0.0	
ct18	Output at READY (Cool)	-10.0 to +110.0%	0.0	
ct19	Output operation at changing AUTOMANUAL	0: Bumpless transfer 1: Preset	0	
ct20	Preset MANUAL value	-10.0 to +110.0%	0.0 or 50.0	
ct21	Initial output type of PID control	0: Auto 1: Not initialized 2: Initialized	0	
ct22	Initial output of PID control	-10.0 to +110.0%	0.0 or 50.0	
ct23	PID decimal point position	0: No decimal point 1: 1 digit after decimal point	0	
ct24	Zone PID operation	0: Disabled 1: Changed by SP 2: Changed by PV	0	
ct26	Heat/Cool control	0: Not used 1: Used	0	
ct27	Heat/Cool selection	0: Normal 1: Energy saving	0	
ct28	Heat/Cool control dead zone	-100.0 to +100.0%	0.0	
ct29	Heat/Cool control change point	-10.0 to +110.0%	50.0	
ct30	LSP system group	1 to 8	1	
ct31	SP ramp type	0: Standard 1: Multi-ramp 2: Step operation When the power is turned ON again, the step operation is stopped (READY) 3: Step operation When the power is turned ON again, the step operation is reset	0	
ct32	SP ramp unit	0: 0.1U/s 1: 0.1U/min 2: 0.1U/h	1	
ct33	STEP time unit	0: 0.1s 1: 1s 2: 1min	0	
ct34	STEP PV start	0: Disabled 1: Enabled	0	
ct35	STEP loop	0: Stop 1: Loop 2: Final step continued	0	
ct36	CT1 operation type	0: Heater burnout detection 1: Current value measurement	0	
ct37	CT1 output	0 to 1: Control output 1 to 2, 2 to 4: Event output 1 to 3	0	
ct38	CT1 measurement wait time	30 to 300ms	30	
ct39	CT2 operation type	Same as CT1	0	
ct40	CT2 output	Same as CT1	0	
ct41	CT2 measurement wait time	Same as CT1	0	
ct42	Control output 1 range	Current output: 1.4 to 20mA 2: 0 to 20mA Continuous voltage output: 1: 1 to 5V 2: 0 to 5V 3: 0 to 10V	1	
ct43	Control output 1 type	0: MV 1: Heat MV 2: Cool MV 3: PV 4: Ratio, bias, and PV before filter 5: SP 6: Deviation 7: CT1 current value 8: CT2 current value 9: Invalid 10: SP+MV 11: PV+MV	0	
ct44	Control output 1 scaling low limit	-1999 to +9999U	0.0	
ct45	Control output 1 scaling high limit		100.0	
ct46	Control output 1 MV scaling	0 to 9999 (Valid when control output 1 type is 10 or 11)	200	
ct47	Control output 2 range	Same as control output 1	0	
ct48	Control output 2 type	Same as control output 1	0	
ct49	Control output 2 scaling low limit	Same as control output 1	0	
ct50	Control output 2 scaling high limit	Same as control output 1	1000	
ct51	Control output 2 MV scaling	Same as control output 1	200	
ct52	Auxiliary output range	Same as control output 1	1	
ct53	Auxiliary type	Same as control output 1	3	
ct54	Auxiliary output scaling low limit	Same as control output 1	0	
ct55	Auxiliary output scaling high limit	Same as control output 1	1000	
ct56	Auxiliary output MV scaling	Same as control output 1	200	
ct57	Position proportional type	0: MFB control + Estimated position control 1: MFB control 2: Estimated position control (MFB disabled) 3: Estimated position control (MFB disabled) + Position adjustment at power ON.	0	
ct58	Position proportional dead zone	0.5 to 25.0%	10.0	
ct59	Motor long life mode	0: Aiming at controllability 1: Aiming at service life of potentiometer	1	
ct60	Motor auto adjust	0: Stop 1: Start	0	
ct61	Input with motor fully closed	0 to 9999	1000	
ct62	Input with motor fully open	0 to 9999	3000	
ct63	Motor full close-full open time	5.0 to 240.0s	30.0	
ct64	CPL/MODBUS	0: CPL 1: MODBUS (ASCII format) 2: MODBUS (RTU format)	0	
ct65	Station address	0 to 127 (Communication is disabled when set at "0")	0	
ct66	Transmission speed (bps)	0: 4800 1: 9600 2: 19200 3: 38400	2	
ct67	Data format (Data length)	0: 7 bits 1: 8 bits	1	
ct68	Data format (Parity)	0: Even parity 1: Odd parity 2: No parity	0	
ct69	Data format (Stop bit)	0: 1 bit 1: 2 bits	0	
ct70	Response time-out	1 to 250ms	3	
ct71	Key operation type	0: Standard type 1: Special type	0	
ct72	[mode] key function	0: Invalid 1: AUTO/MANUAL selection 2: RUN/READY selection 3: AT Stop/Start 4: LSP group selection 5: Release all DO latches 6: Invalid 7: Communication D11 selection 8: Invalid	1	
ct73	MODE display setup (Sum of the weighting)	Bit 0: AUTO/MANUAL display (Enabled: +1) Bit 1: RUN/READY display (Enabled: +2) Bit 2: LSP/RSP display (Enabled: +4) Bit 3: AT Stop/Start display (Enabled: +8) Bit 4: Release all DO latches display (Enabled: +16) Bit 5: Communication D11 ON/OFF display (Enabled: +32) Other invalid setting, 0, +64, +128	255	
ct74	PV/SP display setup (Sum of the weighting)	Bit 0: PV display (Enabled: +1) Bit 1: SP display (Enabled: +2) Bit 2: LSP group number display (Enabled: +4) Other invalid setting, 0, +8	15	

- Items marked ● in the tables are displayed in standard and/or high function configuration.
- To change a user level, refer to **Changing the user level** in the lower right part of this page.

Display	Item	Contents	Initial value	Setting value
㉚5	MV display setup (Sum of the weighting)	Bit 0: MV display (Enabled: +1) Bit 1: Heat MV/cool MV display (Enabled: +2) Bit 2: MFB display (Enabled: +4) Bit 3: AT progress display (Enabled: +8)	15	
㉚6	EV display setup (Operation display)	0: Not displayed 1: Set value of Internal event 1 is displayed 2: Set values of Internal event 1 to 2 are displayed 3: Set values of Internal event 1 to 3 are displayed	0	
㉚7	Timer remain time display setup (Operation display)	0: Not displayed 1: Internal event 1 is displayed 2: Internal event 1 to 2 is displayed 3: Internal event 1 to 3 is displayed	0	
㉚8	CT display setup (Operation display)	0: Not displayed 1: CT1 current value is displayed 2: CT1 to 2 current values are displayed	0	
㉚9	User level	0: Simple configuration 1: Standard configuration 2: High function configuration	1	
㉛0	● Communication monitor display	0: Not used 1: Flashing while data is sending through RS-485 communication 2: Flashing while data is receiving through RS-485 communication 3: Logical OR of all DI statuses 4: Flashing in READY mode	0	
㉛1	● MS display, Condition (top priority)	0: Normally OFF 1: Normally ON 2 to 9: Internal event 1 to 8 10 to 13: Undefined 14: MV1 15: MV2 16 to 17: Undefined 18 to 21: DI1 to 4 22 to 25: Undefined 26 to 30: Internal contact 1 to 5 31 to 33: Undefined 34 to 37: Communication DI 1 to 4 38: MANUAL 39: READY 40: RSP 41: AT 42: During ramp 43: Undefined 44: Alarm 45: PV alarm 46: Undefined 47: [mode] key pressing status 48: Event output 1 terminal status 49: Control output 1 terminal status	39	
㉛2	● MS display, Status (top priority)	0: lit 1: Slow flashing 2: Flashing twice 3: Fast flashing 4: Left to right 5: Right to left 6: Reciprocating between left and right 7: Deviation OK 8: Deviation graph 9: MV graph 10: Heat-side MV graph 11: Cool-side MV graph 12: MFB graph 13: DI monitor 14: Internal contact monitor 15: Internal event monitor	1	
㉛3	● MS display, Condition (secondary priority)	Same as MS display, Condition (top priority)	44	
㉛4	● MS display, Status (secondary priority)	Same as MS display, Status (top priority)	6	
㉛5	● MS display, Condition (third priority)	Same as MS display, Condition (top priority)	1	
㉛6	● MS display, Status (third priority)	Same as MS display, Status (top priority)	9	
㉛7	● MS display, Deviation range	0 to 9999U	5	
㉛8	● Special function	0 to 15 (This value becomes "0" when the power is turned ON.)	0	
㉛9	● Zener barrier adjustment	The value can be changed with the adjustment. The numeric value cannot be directly input with the manual operation.	0.00	
㉜0	● Number of CT1 turns	0: 800 turns 1 to 40: CT turns divided by 100	8	
㉜1	● Number of CT1 power wire loops	0: 1 time 1 to 6: Number of times	1	
㉜2	● Number of CT2 turns	0: 800 turns 1 to 40: CT turns divided by 100	8	
㉜3	● Number of CT2 power wire loops	0: 1 time 1 to 6: Number of times	1	

### ㉜㉜ [Event configuration bank]

Display	Item	Contents	Initial value	Setting value
㉜㉜1 to ㉜㉜3	Internal event 1 to 8 Configuration 1 Operation type	Refer to event type (see page 8)	0	
㉜㉜4 to ㉜㉜6	Internal event 1 to 8 Configuration 2 Operation type	The digits are determined to 1st, 2nd, 3rd, and 4th digit from the right end. 1st digit: Direct/Reverse 0: Direct 1: Reverse 2nd digit: Standby 0: None 1: Standby 2: Standby + Standby at SP change 3rd digit: EVENT state at READY 0: Continue 1: Forced OFF 4th digit: Undefined 0	0	
㉜㉜7 to ㉜㉜9	Internal event 1 to 8 Configuration 3	The digits are determined to 1st, 2nd, 3rd, and 4th digit from the right end. 1st digit: Controller alarm OR 0: None 1: Alarm direct + OR operation 2: Alarm direct + AND operation 3: Alarm reverse + OR operation 4: Alarm reverse + AND operation 2nd digit: Special OFF setup 0: As usual 1: When the event set value (main setting) is 0, the event is "OFF". 3rd digit: Delay unit 0: 0.1s 1: 1s 2: 1min 4th digit: Undefined 0	0	

### ㉜ [DI assignment bank]

Display	Item	Contents	Initial value	Setting value
㉜1 to ㉜5	Internal contact 1 to 5 Operation type	0: No function 1: LSP group selection (0/+1) 2: LSP group selection (0/+2) 3: LSP group selection (0/+4) 4: PID group selection (0/+1) 5: PID group selection (0/+2) 6: PID group selection (0/+4) 7: RUN/READY selection 8: AUTO/MANUAL selection 9: LSP/RSP selection 10: AT Stop/Start 11: Invalid 12: Control action direct/reverse 13: SP Ramp enabled/disabled 14: PV Hold 15: PV Maximum value hold 16: PV Minimum value hold 17: Timer Stop/Start 18: Release all DO latches (Continue/Release) 19: Advance 20: Invalid	0	
㉜2 to ㉜5	Internal contact 1 to 5 Input bit function	0: Not used (Default input) 1: Function 1 ((A and B) or (C and D)) 2: Function 2 ((A or B) and (C or D)) 3: Function 3 (A or B or C or D) 4: Function 4 (A and B and C and D)	0	
㉜3 to ㉜5	Internal contact 1 to 5 Input assign A	0: Normally opened 1: Normally closed 2 to 5: DI1 to 4 6 to 9: Undefined 10 to 17: Internal Event 1 to 8 18 to 21: Communication DI1 to 4 22: MANUAL 23: READY 24: RSP 25: AT running 26: During SP ramp 27: Undefined 28: Alarm occurs 29: PV alarm occurs 30: Undefined 31: mode key pressing status 32: Event output 1 status 33: Control output 1 status	2: Contact 1 3: Contact 2 4: Contact 3 5: Contact 4	
㉜4 to ㉜5	Internal contact 1 to 5 Input assign B		0	
㉜5 to ㉜5	Internal contact 1 to 5 Input assign C		0	
㉜6 to ㉜5	Internal contact 1 to 5 Input assign D		0	
㉜7 to ㉜7	Internal contact 1 to 5 Polarity A to D	The digits are determined to 1st, 2nd, 3rd and 4th digit from the right end. 0: Direct 1: Reverse	0	
㉜8 to ㉜8	Internal contact 1 to 5 Polarity	0: Direct 1: Reverse	0	
㉜9 to ㉜9	Internal contact 1 to 5 Event channel def.	0: Every Internal Event 1 to 8: Internal Event No.	0	

### ⚠ Precaution for setup

- The type of auto tuning can be changed by changing the value of ㉚㉚ (AT type) in the extended tuning bank. Set it to match the control characteristics.
- Be sure the motor is adjusted: ㉚㉚ (motor auto adjust: start) in the setup bank.
- The result of AT control on a position proportioning model is that derivative time (D) = 0. If satisfactory control cannot be obtained, set ㉚㉚ (AT derivative time adjust, in the extended tuning bank) to 1.00.

### ㉜ [DO assignment bank]

Display	Item	Contents	Initial value	Setting value
㉜1 to ㉜3	Operation type (Control output 1 to 2, Event output 1 to 3)	0: Default output 1 to 2: MV1 to 2 3 to 6: Function 1 to 4	0	
㉜2 to ㉜3	Output assign A (Control output 1 to 2, Event output 1 to 3)	0: Normally opened 1: Normally closed 2 to 9: Internal Event 1 to 8 10 to 13: Undefined 14 to 15: MV1 to 2 16 to 17: Undefined 18 to 21: DI1 to 4 22 to 25: Undefined	14: Output 1 15: Output 2 2: Event 1 3: Event 2 4: Event 3	
㉜3 to ㉜3	Output assign B (Control output 1 to 2, Event output 1 to 3)	26 to 30: Internal Contact 1 to 5 31 to 33: Undefined 34 to 37: DI1 to 4 38: MANUAL 39: READY 40: RSP	0	
㉜4 to ㉜4	Output assign C (Control output 1 to 2, Event output 1 to 3)	41: AT running 42: During SP ramp 43: Undefined 44: Alarm occurs 45: PV alarm occurs 46: Undefined 47: Mode key pressing status	0	
㉜5 to ㉜5	Output assign D (Control output 1 to 2, Event output 1 to 3)	48: Event output 1 status 49: Control output 1 status	0	
㉜6 to ㉜6	Control output 1 to 2, Event output 1 to 3 Polarity A to D	The digits are determined to 1st, 2nd, 3rd, and 4th digit from the right end. 0: Direct 1: Reverse	0	
㉜7 to ㉜7	Polarity (Control output 1 to 2, Event output 1 to 3)	0: Direct 1: Reverse	0	
㉜8 to ㉜8	Latch (Control output 1 to 2, Event output 1 to 3)	0: None 1: Latch (Latch at ON) 2: Latch (Latch at OFF except for initialization at power ON)	0	

### ㉜ [User function bank]

Display	Item	Contents	Initial value	Setting value
㉜1 to ㉜8	User function 1 to 8	—	—	

### ㉜ [Lock bank]

Display	Item	Contents	Initial value	Setting value
㉜	Key lock	0: All settings are possible 1: Mode, event, operation display, SP, UF, lock, manual MV can be set 2: Operation display, SP, UF, lock, manual MV can be set 3: UF, lock, manual MV can be set	0	
㉜㉜	Communication lock	0: read/write enabled 1: read/write disabled	0	
㉜㉜	Loader lock	0: read/write enabled 1: read/write disabled	0	
㉜㉜	Password display	0 to 15: Password 1A to 2B display	0	
㉜㉜	Password 1A	0000 to FFFF (Hexadecimal value)	0000	
㉜㉜	Password 2A	0000 to FFFF (Hexadecimal value)	0000	
㉜㉜	Password 1B	0000 to FFFF (Hexadecimal value)	0000	
㉜㉜	Password 2B	0000 to FFFF (Hexadecimal value)	0000	

### ㉜ [Instrument information bank]

Display	Item	Contents	Initial value	Setting value
㉜01	ROM ID	2: Fixed	Disabled	
㉜02	ROM Version 1	XX.XX (2 digits after decimal point)	Disabled	
㉜03	ROM Version 2	XX.XX (2 digits after decimal point)	Disabled	
㉜04	Loader information		Disabled	
㉜05	EST information		Disabled	
㉜06	Manufacturing date code (year)	Subtract 2000 from the year. Example: "3" means the year 2003.	Disabled	
㉜07	Manufacturing date code (month, day)	Month - day divided by 100. Example: "12.01" means the 1st day of December.	Disabled	
㉜08	Serial No.		Disabled	

## Changing the user level

This controller's user level can be set to 1 of 3 types in setup C79. The number of possible displays and settings decreases according to the user level: high function > standard > simple. All items are displayed when high function is selected.

**1**

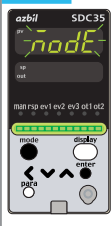

If necessary, press [mode] once to change to the operation display. Next, press and hold [para] for more than 2 seconds to get the parameter setup display. mode flashes on the upper display.

**2**



Press [v] or [∧] repeatedly as needed to get STUP flashing on the upper display.

**3**



Press [enter]. 79 is shown on the upper display. Press [∧], [v] or [∧] to change to ㉚9 (user level).

**4**



When [enter] is pressed, the lower display flashes. Press [v] or [∧] to change to the desired setting, and press [enter] to finalize your selection.

0: Simple configuration  
1: Standard configuration (initial value)  
2: High function configuration

## PV input range table

### [Thermocouple]

C01 Set value	Sensor type	Range
1	K	-200 to +1200°C
2	K	0 to 1200°C
3	K	0.0 to 800.0°C
4	K	0.0 to 600.0°C
5	K	0.0 to 400.0°C
6	K	-200.0 to +400.0°C
7	K	-200.0 to +200.0°C
8	J	0 to 1200°C
9	J	0.0 to 800.0°C
10	J	0.0 to 600.0°C
11	J	-200.0 to +400.0°C
12	E	0.0 to 800.0°C
13	E	0.0 to 600.0°C
14	T	-200.0 to +400.0°C
15	R	0 to 1600°C
16	S	0 to 1600°C
17	B	0 to 1800°C
18	N	0 to 1300°C
19	PL II	0 to 1300°C
20	WRe5-26	0 to 1400°C
21	WRe5-26	0 to 2300°C
22	Ni-Ni-Mo	0 to 1300°C
23	PR40-20	0 to 1900°C
24	DIN U	-200.0 to +400.0°C
25	DIN L	-100.0 to +800.0°C
26	Gold iron chromel	0.0K to 360.0K

### [RTD]

C01 Set value	Sensor type	Range
41	Pt100	-200.0 to +500.0°C
42	JPt100	-200.0 to +500.0°C
43	Pt100	-200.0 to +200.0°C
44	JPt100	-200.0 to +200.0°C
45	Pt100	-100.0 to +300.0°C
46	JPt100	-100.0 to +300.0°C
47	Pt100	-100.0 to +200.0°C
48	JPt100	-100.0 to +200.0°C
49	Pt100	-100.0 to +150.0°C
50	JPt100	-100.0 to +150.0°C
51	Pt100	-50.0 to +200.0°C
52	JPt100	-50.0 to +200.0°C
53	Pt100	-50.0 to +100.0°C
54	JPt100	-50.0 to +100.0°C
55	Pt100	-60.0 to +40.0°C
56	JPt100	-60.0 to +40.0°C
57	Pt100	-40.0 to +60.0°C
58	JPt100	-40.0 to +60.0°C
59	Pt100	-10.00 to +60.00°C
60	JPt100	-10.00 to +60.00°C
61	Pt100	0.0 to 100.0°C
62	JPt100	0.0 to 100.0°C
63	Pt100	0.0 to 200.0°C
64	JPt100	0.0 to 200.0°C
65	Pt100	0.0 to 300.0°C
66	JPt100	0.0 to 300.0°C
67	Pt100	0.0 to 500.0°C
68	JPt100	0.0 to 500.0°C

### [DC voltage/DC current]

C01 Set value	Sensor type	Range
81	0 to 10mV	Scaling range is -1999 to +9999.
82	-10 to +10mV	
83	0 to 100mV	
84	0 to 1V	
86	1 to 5V	
87	0 to 5V	
88	0 to 10V	
89	0 to 20mA	
90	4 to 20mA	

Initial value

\*1: If the ROM version 1 of the instrument information bank (i.e. 2.04) is prior to 2.04, a setting of "3" for the PV input range type (i.e. 3) will result in display of the K thermocouple 0 to 800°C range with no decimal point.

\*2: The indicated low limit for a B thermocouple is 20°C. However, if ROM version 1 of the instrument information bank (i.e. 2.04) is prior to 2.04, the value is -180°C.

## List of alarm code

Alarm code	Failure name	Cause	Corrective action	
Input failure	R101	PV input failure (Over-range)	Sensor burnout, incorrect wiring, incorrect PV input type setting	Check the wiring. Set the PV input type again.
	R102	PV input failure (Under-range)	Sensor burnout, incorrect wiring, incorrect PV input type setting	Check the wiring. Set the PV input type again.
	R103	CJ failure	Terminal temperature is faulty (thermocouple).	Check the ambient temperature.
		PV input failure (RTD)	Sensor burnout, incorrect wiring	Check the wiring.
	R105	RSP input failure (Over-range) (Displayed in RSP mode)	Sensor burnout, incorrect wiring, incorrect RSP input type setting	Check the wiring. Set the RSP input type again.
	R106	RSP input failure (Under-range) (Displayed in RSP mode)	Sensor burnout, incorrect wiring, incorrect RSP input type setting	Check the wiring. Set the RSP input type again.
	R107	MFB input failure	Burnout, incorrect wiring	Check the wiring. Check the MFB input value.
R110	Motor adjustment failure	Burnout, incorrect wiring. Power for motor is shut-down.	Check the wiring. Adjust the motor again after checking the power for motor.	
R111	CT input failure (Over-range) (CT input 1 or 2, or both)	A current exceeding the upper limit of the display range was measured. The number of CT turns or the number of CT power wire loops is incorrectly set, or wiring is incorrect.	<ul style="list-style-type: none"> <li>Use a CT with the correct number of turns for the display range.</li> <li>Reset the number of CT turns.</li> <li>Reset the number of CT power wire loops.</li> <li>Check the wiring.</li> </ul>	
R112	A/D conversion failure	A/D converter is faulty.	Replace the unit.	
R195	Parameter failure	Power is shut-down while the data is being set, or data is corrupted by noise.	<ul style="list-style-type: none"> <li>Restart the unit.</li> <li>Set the data again (set data for R195/97 and adjustment data for R195/98).</li> <li>Replace the unit.</li> </ul>	
R196	Adjustment data failure	Power is shut-down while the data is being set, or data is corrupted by noise.	<ul style="list-style-type: none"> <li>Restart the unit.</li> <li>Set the data again (set data for R195/97 and adjustment data for R195/98).</li> <li>Replace the unit.</li> </ul>	
R197	Parameter failure (RAM area)	Data is corrupted by noise.	<ul style="list-style-type: none"> <li>Restart the unit.</li> <li>Set the data again (set data for R195/97 and adjustment data for R195/98).</li> <li>Replace the unit.</li> </ul>	
R198	Adjustment data failure (RAM area)	Data is corrupted by noise.	<ul style="list-style-type: none"> <li>Restart the unit.</li> <li>Set the data again (set data for R195/97 and adjustment data for R195/98).</li> <li>Replace the unit.</li> </ul>	
R199	ROM failure	ROM (memory) is faulty.	<ul style="list-style-type: none"> <li>Reset the unit.</li> <li>Replace the unit.</li> </ul>	

### Handling precautions

- If ROM version 1 of the instrument information bank (i.e. 2.04) is prior to 2.04, CT input failure (R111) is not displayed.

## Event type

Operation type	Set value	Direct action	Reverse action
No event	0	Always OFF	Always OFF
PV high limit	1		
PV low limit	2		
PV high/low limit	3		
Deviation high limit	4		
Deviation low limit	5		
Deviation high/low limit	6		
Deviation high limit (Final SP reference)	7		
Deviation low limit (Final SP reference)	8		
Deviation high/low limit (Final SP reference)	9		
Heater 1 burnout/Over-current	16		
Heater 1 short-circuit	17		
Heater 2 burnout/Over-current	18		
Heater 2 short-circuit	19		
Alarm (status)	23	ON if alarm occurs (alarm code AL01 to 99). OFF in other cases.	OFF if alarm occurs (alarm code AL01 to 99). ON in other cases.
High and low limits of MFB value	33		

Initial value

\*: If the main setting is greater than the sub-setting, operations are performed with the main setting and sub-setting automatically swapped.

### Event types other than the above:

Operation type	Set value	Operation type	Set value	Operation type	Set value
SP high limit	10	Loop diagnosis 1	20	During AT (status)	27
SP low limit	11	Loop diagnosis 2	21	During SP ramp	28
SP high/low limit	12	Loop diagnosis 3	22	Control action (status)	29
MV high limit	13	READY (status)	24	ST setting standby (status)	30
MV low limit	14	MANUAL (status)	25	Estimated position control (status)	31
MV high/low limit	15	RSP (status)	26	Timer (status)	32

### Handling precautions

- If ROM version 1 of the instrument information bank (i.e. 2.04) is prior to 2.04, "33" cannot be set as [Internal Event configuration 1 operation type].

**azbil**

Specifications are subject to change without notice.

**Yamatake Corporation**  
Advanced Automation Company

1-12-2 Kawana, Fujisawa  
Kanagawa 251-8522 Japan

Printed in Japan.

URL: <http://www.azbil.com>

1st Edition: Issued in Dec. 2007 (W)

Printed on recycled paper. (07)