

LJS-A Series

Solid die-cast safety interlock switches.

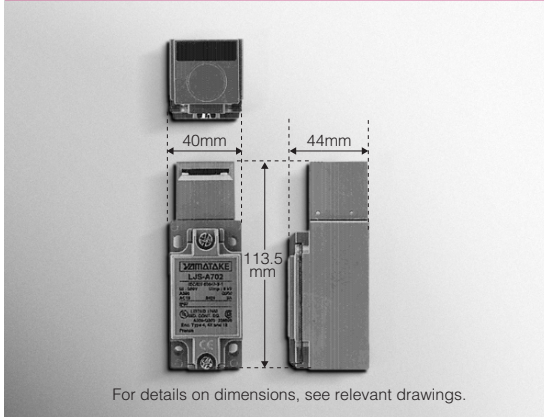

- UL/CSA/CE markings
- ⊖ Forced contact-opening mechanism (N.C. contact only)
- Superior IP67 seal





ORDER GUIDE

• Body

Contact type	Catalog listing
N.C. × 1 + N.O. × 2	LJS-A502
N.C. × 2 + N.O. × 1	LJS-A702

• Tongued key

Shape	Catalog listing
Straight type 	LJS-Z01
Right angle type 	LJS-Z02
Adjustable type 	LJS-Z03

INTERNAL SWITCH

The internal switch of the **LJS-A** Series has the N.C./N.O. electrically independent contact (Zb) structure.

Additionally, the contact forced open structure is used to forcibly open the contact (N.C. contact only) even if the contact is fused accidentally.

As the switch is pushed in, the contact is opened forcibly.

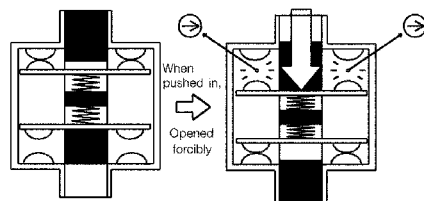

PERFORMANCE

Standards	Conformed standards	Product related: IEC 60947-5-1, EN 60947-5-1 ⊕ Machine related: IEC 60204-1, EN 60204-1, EN 1088
	Approved standards	UL/CSA
Structure	Protective structure	IP67 (IEC 60529)
	Electrical shock protection	class I (IEC 60536)
	Contamination degree of operating environment	Contamination degree 3
Electrical performance	Electrical rating	See separate Table 1.
	Rated energizing current (Ith)	10A
	Short-circuit protective device	Breaking fuse 10A type gG (gl)
	Rated insulation voltage (UI)	500V IEC 60947-1, 300V UL508
	Conditional rated short-circuit current	1,000A
	Rated impulse withstanding voltage (Uimp)	6,000V
Mechanical performance	Impact resistance	100m/s ² (11ms) IEC 60068-2-27
	Vibration resistance	50m/s ² (10 to 500Hz) IEC 60068-2-6
	Minimum operating speed	0.01m/s
	Maximum operating speed	0.5m/s
Life	Mechanical life	1,000,000 operations or more
	Electrical life	500,000 operations or more
Environmental conditions	Operating temperature range	-25 to +70°C (No freezing allowed.)
	Storage temperature range	-40 to +70°C
	Operating humidity range	85%RH or less
Recommended tightening torque	Body	5 to 6N-m (M5 hexagon socket head cap bolt)
	Cover	2.7 to 3.0N-m (M5 flat fillister head screw) 1.3 to 1.7N-m (M4 flat fillister head screw)
	Terminal	0.8N-m (M3 binding machine screw)

● Table 1. Electrical rating

AC-15: A300 (Ue=240V, Ie=3A or Ue=120V, Ie=6A)
DC-13: Q300 (Ue=250V, Ie=0.27A or Ue=125V, Ie=0.55A)

AC-15: Solenoid load

DC-13: Solenoid load

Ue: Rated operating voltage

Ie: Rated operating current

CONTACT OPERATION

Catalog listing	LJS-A502	LJS-A702
<p>■ : Contact close</p> <p>□ : Contact open</p> <p>▨ : Transient state</p>	<p>Tongued key insertion (NORMAL) state</p>	<p>Tongued key insertion (NORMAL) state</p>
Circuit diagram		

OPERATING CHARACTERISTICS AND EXTERNAL DIMENSIONS

(unit: mm)

• Body

• LJS-A□02

Tongued key removal strength	20N
Forced opening force (Min.)	20N

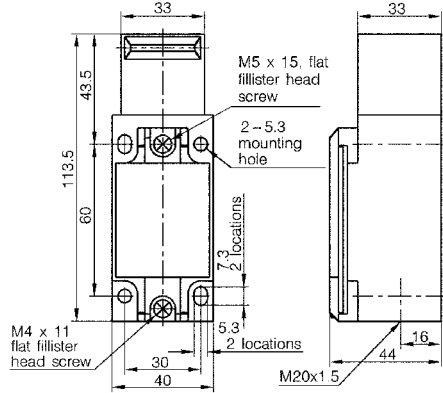

• Tongued key

LJS-Z01

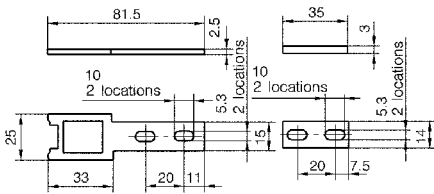

LJS-Z02

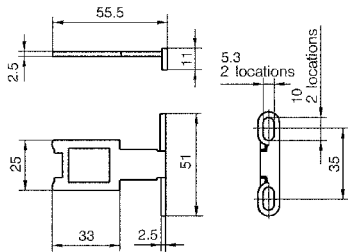

LJS-Z03

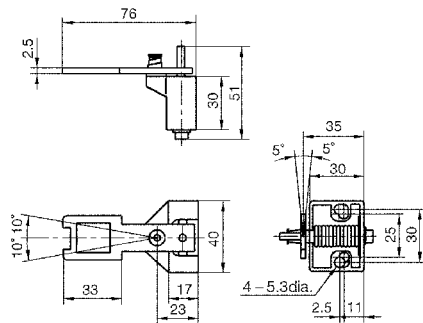

• Diagram of tongued key position

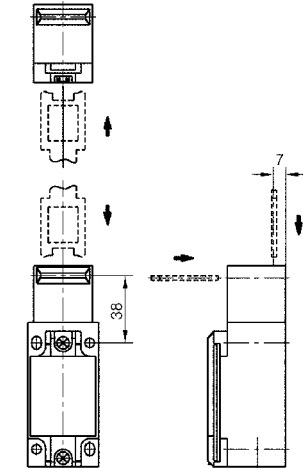

• Diagram of tongued key insertion position

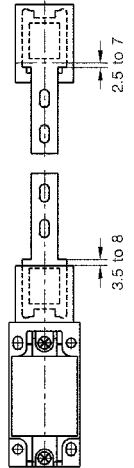

(unit: mm)

● Actuation radius of tongued key

LJS-Z01/Z02

(unit: mm)
(unit: mm)

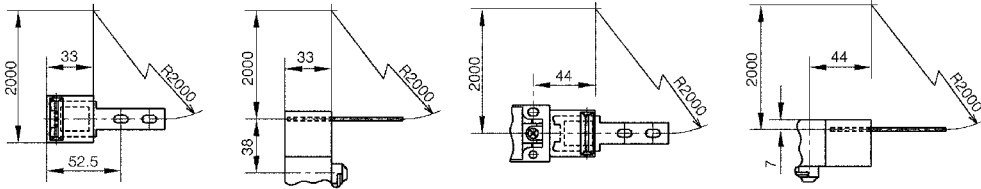

LJS-Z03

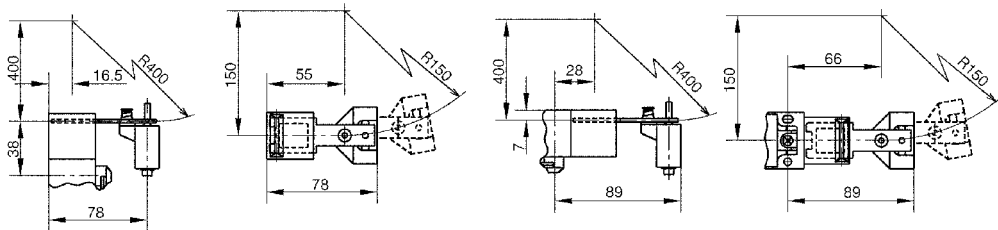

HANDLING PRECAUTIONS

● Mounting the switch

- Always tighten each part of the safety switch with the recommended tightening torque stated in the product specification. If any part is tightened excessively, this might cause damage to the screw and/or other parts. Additionally, insufficient tightening may lead to lowering of various characteristics, such as switch sealing ability.
- Regardless of the door type, do not use the safety switch for the door stopper.
A mechanical door stopper is installed at the end of the door so that any excessive force is not applied to the safety switch.
- Do not apply any excessive impact to the safety switch by opening or closing the door carelessly. If any excessive impact is applied to the switch, this might cause the switch to malfunction.
- When the safety switch is operated in a place where a large amount of foreign matter or dust exists, appropriate measures, such as protective cover are taken to prevent foreign matter or dust from entering the safety switch through the tongued key insertion port. If a large amount of foreign matter or dust enters the safety switch, this may affect the mechanical part, resulting in malfunction.

● Tongued key

- Do not use any tongued key other than that specified. Operation with a tongued key other than that specified might cause the switch to break.
- Mount the tongued key in a place where it is not in contact with the operator's body when opening or closing the door. Failure to do so might cause personal injury.