

Switching Output Laser Sensors

HLA Series

High-accuracy detection of very small targets using the direct reflection method.



- Detecting a long distant and very small spot. Switching output type: 0.1mm dia. at 80mm
- Line-up of “contrast setting” and “distance setting” types for the switching output type



EXPLANATION ON FEATURES

● Long distance and minute spot

Realized the detection of 0.1mm spot diameter with the switching output type of 80mm.

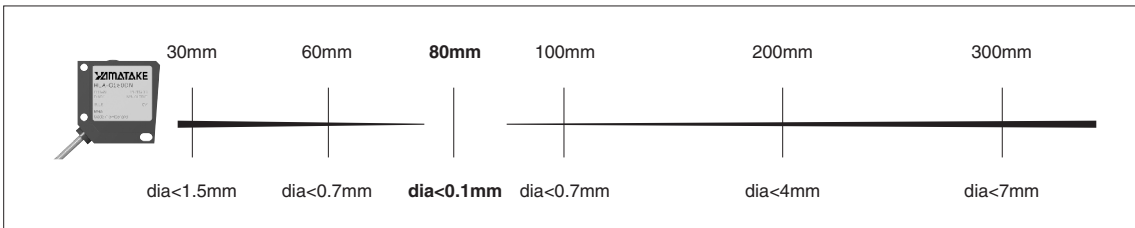

● “Contrast Setting”, “Distance Setting”

Distance setting type HLA-D300D

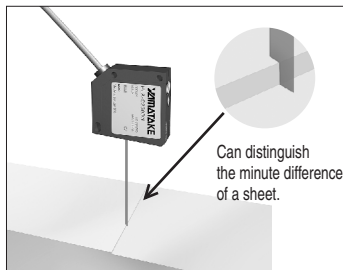

Contrast setting type HLA-C250D

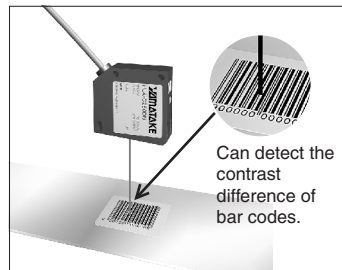

● High speed detection

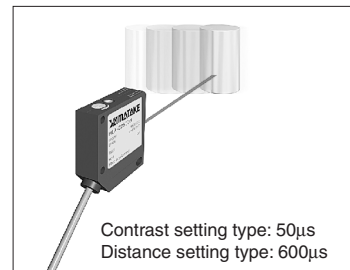

CATALOG LISTING

Type	External appearance	Detecting distance	Power supply	Output Actuation	Catalog listing
Switching output contrast setting reflective	250mm max. (focal distance 80mm)	18 to 30Vdc	NPN(with pull-up)	Light ON	HLA-C250DN
Switching output distance setting reflective	25 to 300mm (focal distance 80mm)	10 to 30Vdc	NPN(with pull-up)	Light ON/Dark ON (separate output)	HLA-D300DN

SPECIFICATIONS

Type	Contrast setting reflective	Distance setting reflective
Catalog listing	HLA-C250DN	HLA-D300DN
Power supply	18 to 30Vdc, with protective circuit for reverse connection	10 to 30Vdc, with protective circuit for reverse connection
Consumption current	65mA	75mA
Detecting distance	100 to 250mm	25 to 300mm
Focal distance	80mm	80mm
Focal spot diameter	0.1mm dia. max. (at focal distance)	
Operation mode	Light ON	Light ON / Dark ON separate output
Output	NPN (with pull-up) *	
Control output	Load current: 200mA max., Saturation voltage: 1.8V max., Short circuit protection	
Response time	50μs max. for actuation/release	600μs max. for actuation/release
Sensitivity adjustment	14-turn potentiometer	8-turn potentiometer
Casting beam	Laser diode of 675nm, class 2 (21CFR 1040.10)	
Indication	Output indicator (yellow), Supply indicator (green)	
Ambient temperature	-10 to +50°C	
Wiring	Brown: Vcc, Black: output, Blue: 0V	
Protection	IP67	

* The sensor can be connected to a voltage input device without the addition of a pull-up resistor to the input device side. Connecting the sensor to an input device whose power supply voltage is different from that of the sensor might create difficulties. In such a case, contact Yamatake Corporation first.

EXTERNAL DIMENSIONS

(unit: mm)

HLA-C250DN

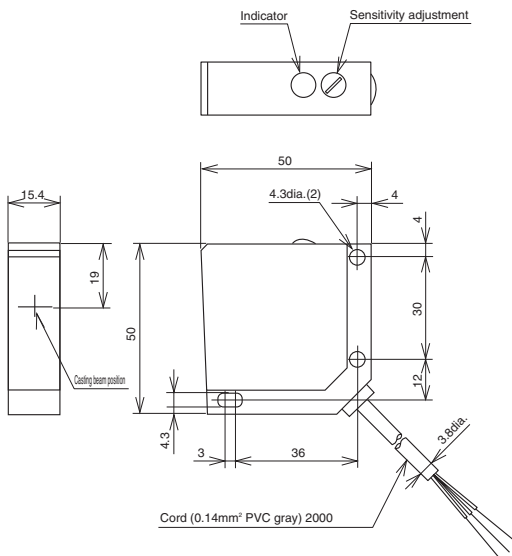

HLA-D300DN

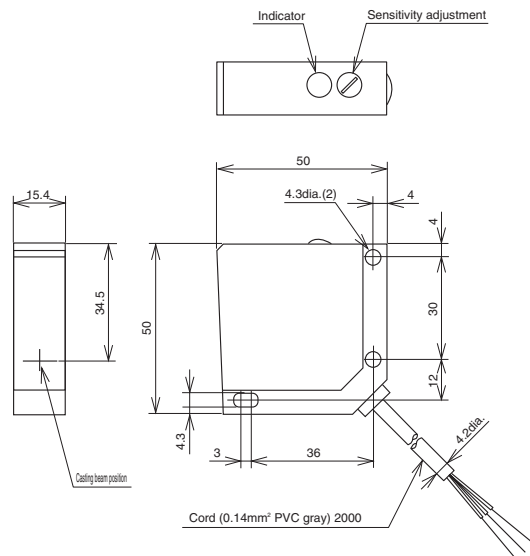

OUTPUT CIRCUIT

HLA-C250DN

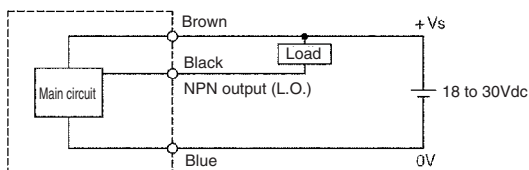

HLA-D300DN

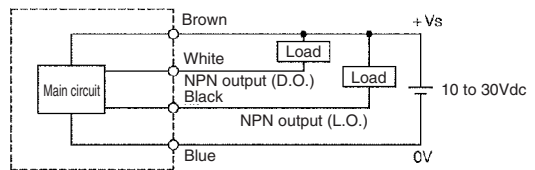

NOTES FOR USE OF HLA SERIES WITH SWITCHING OUTPUT

1. Laser beam spot diameter

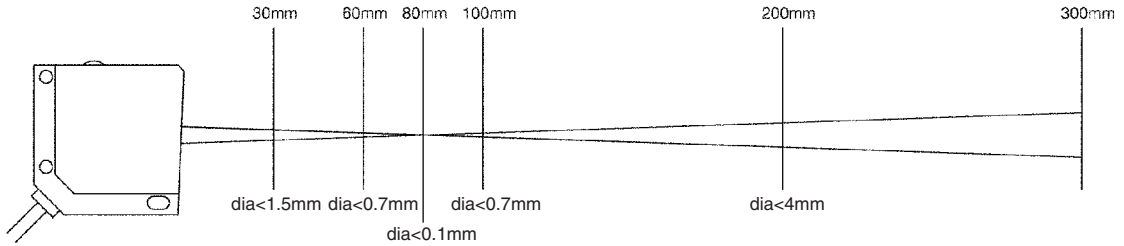

⚠ WARNING

Precautions related to laser light

- This is a JIS (Japan Industrial Standards) Class 2 laser product.
- Avoid looking directly at the laser beam or a specular reflection of the beam. Never point the beam toward someone's eye.
- Provide shielding so that the human body is not directly exposed to laser radiation.



- For safety, stop the laser beam at the end of its path with a diffuse reflecting or absorbing surface having suitable reflectance and temperature properties.
- If the installation conditions make the laser warning label difficult to read, before using the laser be sure to post the enclosed warning label in a place where its details can be read easily.

2. Precautions for use

2.1 Handling precautions

- Mount using M4 screws in the three mounting holes.
- Sensor requires about 75ms to stabilize after power is supplied.
- If installed outdoors, the sensor should be placed in a housing to prevent direct exposure to the sun or rain.
- Avoid installing the sensor where there is strong vibration or impact, since they might shift the optical axis out of alignment.
- Shield the lens so that it is not directly exposed to water or oil. If it is splashed, malfunction could result.
- Where there is heavy interference from ambient light, shade the sensor with a hood or change the mounting direction to prevent malfunction.
- In the sensor is used in a dusty place, put it in a sealed case or use air purging or other countermeasures to prevent dust from accumulating on the lens.
- The laser sensor is assembled with high precision. Never strike it with another object. In particular, if the lens surface is scratched or cracked, its properties may be impaired.
- If the lens is dirty, wipe it with a soft, dry, clean cloth. If it is especially dirty, clean it with pure alcohol.
- If multiple sensors are used close together, performance may be adversely affected. After installing and before use, check carefully to be sure there is no mutual interference.
- Highly reflective metal surfaces near the laser sensor may cause malfunction. Dull or paint nearby metal surfaces so that they are not reflective.

2.2 Precautions for wiring

- Be sure to turn off the power before mounting the sensor.
- Route the laser sensor wiring separately or in its own conduit. If it is put in the same conduit with high voltage lines or power lines, induction may cause malfunction or damage.
- When using a commercially available switching regulator, ground the frame ground terminal. Otherwise, switching noise could cause a malfunction.
- When using a load that generates an inrush current, such as a capacitive load or lamp load, connect a current-limiting resistor between the load and the output terminal. (Otherwise, the output short-circuit protection may be activated.)
- This sensor has miswiring protection, but it may be damaged by incorrect wiring involving the I/O lines. Be sure to wire correctly.